



QUICK SELECTION / Selezione veloce input speed (n₁) = 1400 min⁻¹

Output Speed n ₂ [min ⁻¹]	Ratio i	Motor power P _{1M} [kW]	Output torque M _{2M} [Nm]	Service factor f.s.	Nominal power P _{1R} [kW]	Nominal torque M _{2R} [Nm]	Available B5 motor flanges				Available B14 motor flanges				Output Shaft 	Ratios code
							-D	-E	-F	-G	-R	-T	-U	-V		
							80	90	100 112	132	80	90	100 112	132		
364.3	3.84	9	227	1.5	13.91	350									3317	01
257.5	5.44	9	321	1.1	10.11	360									3313	02
233.3	6.00	9	354	1.1	9.67	380									3312	03
187.5	7.47	9	440	1.0	8.59	420									3310	04
165.1	8.48	9	500	1.0	8.64	480									2513	05
149.6	9.36	7.5	444	1.1	8.16	500									2512	06
120.2	11.65	7.5	553	1.1	8.00	610									2510	07
97.3	14.39	5.5	504	1.2	6.69	630									1713	08
88.1	15.88	5.5	557	1.2	6.35	660									1712	09
70.8	19.76	5.5	693	1.0	5.22	675									1710	10
63.4	22.08	4	566	1.2	4.67	675									1213	11
57.4	24.38	4	625	1.1	4.23	675									1212	12
46.2	30.33	3	586	1.2	3.40	675									1210	13
41.2	34.00	3	656	1.0	3.03	675									912	14
36.1	38.81	2.2	552	1.2	2.66	675									812	15
33.1	42.31	2.2	601	1.1	2.44	675									910	16
29.0	48.30	2.2	687	1.0	2.13	675									810	17

The dynamic efficiency is **0.96** for all ratios

Motor Flanges Available Flange Motore Disponibili
 B) Supplied with Reduction Bushing Fornito con Bussola di Riduzione
 B) Available on Request without reduction bushing Disponibile a Richiesta senza Bussola di Riduzione
 C) Motor Flange Holes Position Posizione Fori Flangia Motore

EN Unit **712C** is supplied with synthetic oil for lifetime lubrication, no maintenance is necessary. See table 1 for lubrication and recommended quantity. In table 2 please see possible radial loads and axial loads on the gearbox.

I Il riduttore **712C** viene fornito completo di olio sintetico per la lubrificazione permanente e non necessita di alcuna manutenzione. Vedi tab.1 per oli e quantità consigliati. In tab.2 sono presenti i carichi radiali e assiali applicabili al riduttore.

D Das Getriebe **712C** ist mit synthetischem Öl gefüllt und ist lebensdauergeschmiert. In Tabelle 1 ist die Schmiermenge und das empfohlene Schmiermittel angegeben. In Tabelle 2 sind die zulässigen Radial - und Axialbelastungen des Getriebes aufgeführt.

F Le réducteur **712C** est fourni complet avec de l'huile synthétique pour la lubrification permanente et ne nécessite aucun entretien. Voir tableau 1 concernant les huiles et les quantités conseillées. Les charges radiales et axiales applicables au réducteur sont précisées dans le tableau 2.

E El reductor tamaño **712C** se suministra, lubricado de por vida con aceite sintético y no requieren mantenimiento alguna. Ver tabla 1, para cantidades y aceites recomendados. En la tabla 2, se encuentran las cargas radiales y axiales admitidas por el reductor.

B3	B6	B7	B8	V5	V6	V8
1.50 LT	2.30 LT	1.90 LT	1.70 LT	2.60 LT	2.00 LT	Ask
SHELL Omala S4 WE 320				ENI Telium VSF 320		

For all details on lubrication and plugs check our website **tab. 1**
Per maggiori dettagli su lubrificazione e tappi olio vedi il nostro sito web

RADIAL AND AXIAL LOADS

Output shaft
Albero di uscita

FR (N)
FA (N)

$$F_{eq} = FR \cdot \frac{78}{X+38}$$

Feq (N)

n ₂	FA	FR	n ₂	FA	FR	n ₂	FA	FR
300	680	3400	140	960	4800	70	1300	6500
250	760	3800	120	1040	5200	40	1460	7300
200	900	4500	85	1120	5600	15	1800	9000

On request reinforced bearings to increase loads.
A richiesta cuscinetti rinforzati per aumentare i carichi.

Input shaft
Albero in entrata

n ₁	FA	FR
1400	450	2250
900	500	2500
500	600	3000

tab. 2

P712C**S6**... With feet
Con piedini

Gearbox weight With flange **33.3 kg**
peso riduttore With feet **35.0 kg**

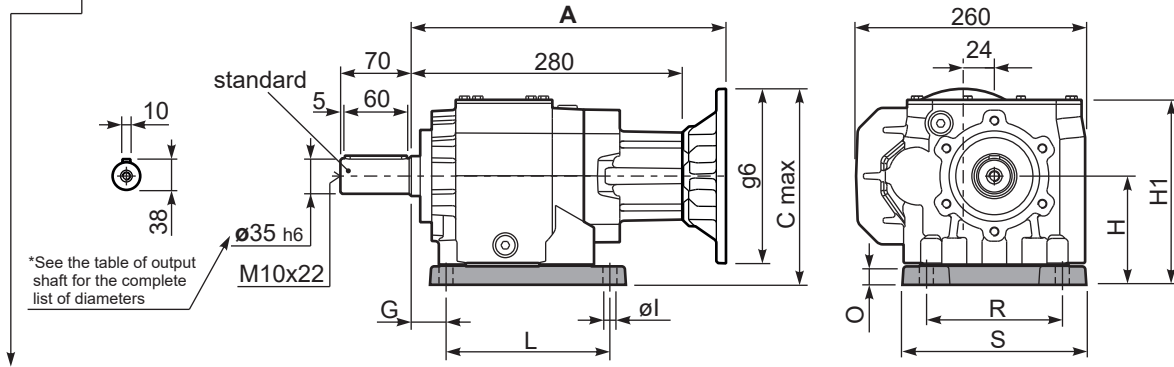

Feet / piedini

Feet Code	Market reference	G	H	R	L	S	H1	O	øl	B5 max. Flange	kit code
B4	412/3	19.5	130	180	149.5	220	220	25	14	-	KC71.9.022
S6	67	30	130	150	195	210	220	25	14	-	KC71.9.024

P712C-**F**... Output flanges
flange di uscita

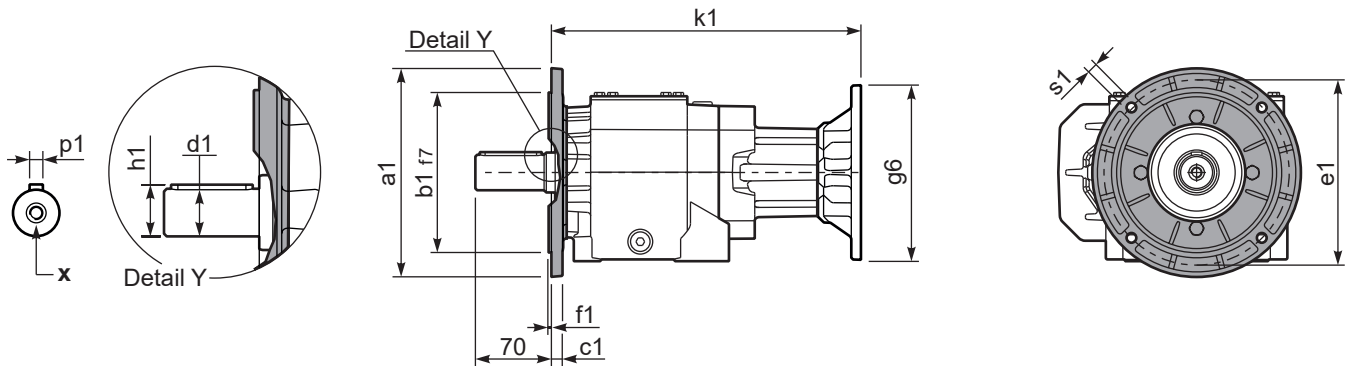

***Available output shaft / Alberi di uscita**

	Shaft - d1	p1	h1	x
Standard	ø 35x70	10	38	M10x22
On request A richiesta	ø 38x70	10	41	M10x25

Available output flanges / flange di uscita

a1 ø	b1	c1	e1	f1	s1	kit code
200	130	11	165	3.5	11	KC71.9.012
250	180	13	215	4	14	KC81.9.013
-	-	-	-	-	-	-

With flange and feet only on request. Ask for compatibility

P712C-**N**... Basic gearbox
Riduttore base

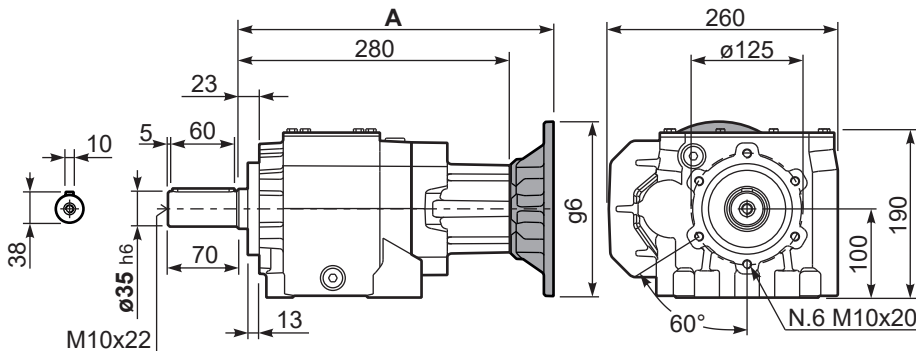

R712C-N... Input Shaft
Albero in entrata

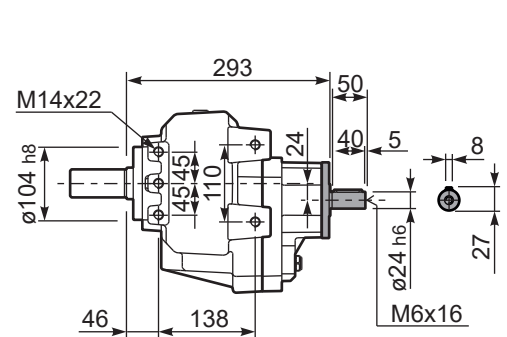

B5 Motor Flanges	A	C _{max}	g6	k1	kit code
80/90 B5	300.5	230	200	300.5	K023.4.042
100/112 B5	309.5	255	250	309.5	K023.4.043
132 B5	331	280	300	331	KC51.4.043C

B14 Motor Flanges	A	C _{max}	g6	k1	kit code
80 B14	300.5	190	120	300.5	K085.4.046
90 B14	300.5	200	140	300.5	K085.4.045
100/112 B14	309.5	210	160	309.5	K085.4.047
132 B14	331	230	200	331	KC51.4.041C