

Low Center Motors

Catalogue

Kemmerich Elektromotoren GmbH & Co. KG
www.elektromotoren.de

EN

Serie C056

Low Center Motors

The range of Low Center Motors is particularly suitable for applications where high power is required with limited axle height compared to the range of motors UNEL – MEC. They are produced in three phase (ET) and single phase versions (EM), 2 and 4 pole. (6 pole on demand). This range is also designed for inverter duty use, for applications where it is necessary to vary the motor frequency to reach speeds greater than 3000 rpms. In building these Low Center Motors, using only the highest quality components and highest grade materials.

Housings have been redesigned. The new design ensure better cooling and increased performance allowing maximum protection from external contaminants. Our side T slots allow for universal mounting and positioning of the terminal box.

Standard couplings are :

- **B3:** with blade discs and fastening bolt
- **B14:** with B14 shaft and flange that meet UNEL/MEC specifications.



B3



B14

Other couplings are available upon request according to DIN6499 (collet ER) and customer specifications.

rated voltage	230/400V 50Hz (Pn ≤ 3 kW) - 400/690V 50Hz (Pn > 3 kW)	ET
	230V 50Hz	EM
protection rating	IP55	
winding insulation class	F	
bearings	deep groove ball bearings	
balancing	norme CEI EN 60034-14	E60 - E63 - E80
duty	S6 - 60%	
efficiency	IE1	
frame	extruded aluminum	
terminal box	two aluminum components	ET
	plastic capacitor holder	EM
fan cover	aluminum	E48
	plastic	E60 - E63 - E80
run capacitor	internal permanently connected	EM
paint finish	natural aluminum	

Performance Data

LEGEND

Size	Pn	n	In	cosf	η	Mn	Mm
frame size	rating power	rating speed	rated current	power factor	efficiency	rated torque	maximum torque

Ms	Is	Cm	J	W	bt	max e
starting torque	locked rotor current	run capacitor	inertia	weight	brake torque	brake max allowable energy

Table refers to the electrical performances data according to the Duty S6 -60% (standard product) and S1 (product on demand).

ETSTD	S6 - 60%									S1									J		W
	Pn	n	In (400V)	cosf	η	Mn	Mm/Mn	Ms/Mn	Is/In	Pn	n	In (400V)	cosf	η	Mn	Mm/Mn	Ms/Mn	Is/In	B3	B14	B3
size	kW	rpm	A		%	Nm				kW	rpm	A		%	Nm				Kgm ²	Kgm ²	Kg
ET48S	0,37	2740	0,92	0,82	67	1,29	2,1	2,1	3,8	0,25	2840	0,78	0,68	68	0,84	3,3	3,3	4,5	0,00050	0,00026	6
ET48S	0,55	2700	1,37	0,85	68	1,95	2	1,9	3,5	0,37	2815	1,03	0,75	69	1,26	3,1	3	4,7	0,00050	0,00026	6
ET48S	0,75	2700	1,91	0,86	66	2,65	2	1,9	3,2	0,55	2800	1,39	0,77	74	1,88	2,8	2,7	4,4	0,00056	0,00032	7
ET48M	1,1	2700	2,55	0,83	75	3,89	2,5	2,5	4	0,75	2800	1,96	0,7	79	2,56	3,8	3,8	5,2	0,00067	0,00042	8,4
ET48M	1,3	2700	3,22	0,8	73	4,6	2,8	2,5	4,5	1,1	2750	2,79	0,76	75	3,82	3,4	3	5,9	0,00077	0,00052	9,7
ET48La	1,5	2700	3,57	0,82	74	5,31	2,4	2,4	3,8	1,3	2750	3,17	0,78	76	4,51	2,8	2,8	4,3	0,00083	0,00059	10
ET48Lb	1,7	2770	4,54	0,72	75	5,86	3	3	4,3	1,5	2800	4,19	0,68	76	5,116	3,4	3,4	4,1	0,00123	0,00066	10,6
ET60S	1,5	2750	3,35	0,85	76	5,21	2,3	2,1	4,5	1,1	2800	2,54	0,8	78	3,75	3,2	2,9	5,9	0,00152	0,00076	14
ET60M	1,8	2790	3,96	0,87	76	6,33	2,4	2,2	4,9	1,5	2835	3,39	0,82	78	5,05	3	2,8	5,7	0,00165	0,00088	15
ET60M	2,2	2800	4,80	0,86	77	7,5	2,7	2,7	6,2	1,85	2840	4,12	0,83	78	6,22	3,2	3,2	7,2	0,00177	0,00100	15,5
ET60L	3	2825	6,70	0,82	79	10,1	3,1	3,1	5,7	2,2	2880	5,51	0,72	80	7,29	4,3	4,3	6,9	0,00202	0,00125	18
ET63S	1,1	2740	2,52	0,83	76	3,83	2,3	2,3	4,7	0,75	2840	1,85	0,76	77	2,52	3,6	3,6	6,5	0,00156	0,00079	10
ET63S	1,5	2700	3,40	0,85	75	5,31	2,6	2,5	4,3	1,1	2800	2,48	0,8	80	3,75	3,7	3,5	5,9	0,00166	0,00089	11,3
ET63S	1,85	2750	4,19	0,85	75	6,42	3	3	4,5	1,5	2800	3,43	0,83	76	5,12	3,8	3,8	5,5	0,00186	0,00109	14
ET63S	2,2	2800	4,67	0,84	81	7,5	3	3	5,7	1,85	2800	4,07	0,8	82	6,2	3,6	3,6	6,5	0,00206	0,00129	14,5
ET63La	2,2	2800	4,67	0,84	81	7,5	3	3	5,7	1,85	2830	4,07	0,8	82	6,2	3,6	3,6	6,5	0,00208	0,00131	15
ET63La	3	2800	6,36	0,84	81	10,2	3,2	3,2	6	2,2	2850	4,96	0,78	82	7,37	4,4	4,4	7,7	0,00238	0,00161	17
ET63Lb	3,7	2760	7,67	0,87	80	12,8	3	2,7	5,9	3	2820	6,36	0,83	82	10,2	3,7	3,4	7,2	0,00267	0,00190	19
ET63Lb	4*	2730	8,30	0,88	79	14	2,7	2,5	5,5												
ET80S	3	2850	6,44	0,83	81	10,1	3,2	3,2	6	2,2	2900	5,16	0,76	81	7,24	4,4	4,4	7,5	0,00750	0,00231	27
ET80S	4	2890	8,80	0,8	82	13,2	3,3	3,3	6,8	3	2920	7,45	0,7	83	9,81	4,4	4,4	8	0,00776	0,00257	27,5
ET80M	5,5	2880	11,70	0,8	85	18,2	3,6	3,5	6,8	4	2920	9,60	0,7	86	13,1	5	4,9	8,3	0,00828	0,00322	31,5
ET80La	7,5	2850	15,20	0,85	84	25,1	3,3	3,3	7,6	5,5	2900	11,80	0,79	85	18,1	4,6	4,6	9,7	0,00945	0,00439	39,8
ET80Lb	9,2	2900	19,60	0,78	87	30,3	4,2	3,5	8	7,5	2930	18,00	0,7	86	24,4	5,2	4,3	8,7	0,01023	0,00521	45
ET80Lb	11*	2880	22,80	0,82	85	36,5	3,5	2,9	6,9	9,2	2900	19,60	0,8	87	30	4,2	3,5	8	0,01028	0,00521	44

* S6 - 40%

Performance Data

ETSTD	S6 - 60%									S1									J		W
4 POLES	Pn	n	In (400V)	cosφ	η	Mn	Mm/Mn	Ms/Mn	Is/In	Pn	n	In (400V)	cosφ	η	Mn	Mm/Mn	Ms/Mn	Is/In	B3	B14	B3
size	kW	rpm	A		%	Nm				kW	rpm	A		%	Nm				Kgm^2	Kgm^2	Kg
ET48S	0,25	1350	0,94	0,66	58	1,77	2,4	2,4	3	0,19	1400	0,87	0,56	55	1,26	4,6	4,6	3,2	0,00057	0,00033	5,4
ET48S	0,37	1400	1,52	0,54	65	2,52	3,9	3,9	3,6	0,30	1430	1,46	0,48	62	2,00	4,9	4,9	3,7	0,00069	0,00045	7,1
ET48M	0,55	1300	1,69	0,7	67	4,04	2,5	2,5	3,2	0,37	1400	1,62	0,5	66	2,52	4	4	3,3	0,00082	0,00058	9
ET48La	0,75	1300	2,31	0,78	60	5,51	2,2	2,2	2,8	0,55	1380	2,13	0,62	60	3,81	3,2	3,2	3	0,00091	0,00067	9,7
ET60S	1,1	1370	2,94	0,75	72	7,67	2,7	2,7	4,4	0,75	1420	2,18	0,7	71	5,04	2,7	2,7	4,9	0,00283	0,00173	12,5
ET60L	1,5	1380	4,18	0,7	74	10,4	2,6	2,6	4,5	1,1	1410	3,35	0,65	73	7,45	3,6	3,6	5,6	0,00279	0,00203	15,5
ET60L	1,8	1390	4,95	0,7	75	12,4	2,5	2,5	4,6	1,5	1400	4,50	0,65	74	10,20	3	3	5,1	0,00318	0,00242	18,5
ET63S	0,75	1380	2,03	0,72	74	5,19	2,1	2	3,5	0,55	1400	1,68	0,62	76	3,75	2,9	2,8	4,2	0,00217	0,00140	11,2
ET63S	1,1	1385	2,71	0,77	76	7,58	2,4	2,3	4	0,75	1440	2,17	0,64	78	4,97	3,6	3,5	5	0,00250	0,00173	12,6
ET63La	1,5	1300	3,86	0,79	71	11	1,8	1,8	3,2	1,1	1360	2,90	0,71	77	7,72	2,6	2,6	4,3	0,00284	0,00207	14,6
ET63La	1,85	1320	4,63	0,78	74	13,4	2,2	2,2	4,1	1,5	1360	3,90	0,73	76	10,50	2,8	2,8	4,9	0,00333	0,00256	15
ET80S	2,2	1400	4,96	0,8	80	15	3	2,7	5	1,85	1420	4,40	0,75	81	12,40	3,6	3,3	5,6	0,01012	0,00494	28,5
ET80M	3	1370	6,77	0,8	80	20,9	2,2	2,2	4,4	2,2	1400	5,23	0,75	81	15,00	3,1	3,1	5,7	0,01018	0,00512	30

EMSTD	S6 - 60%									S1									J		W
2 POLES	Pn	n	In (400V)	cosφ	η	Mn	Mm/Mn	Ms/Mn	Is/In	Pn	n	In (400V)	cosφ	η	Mn	Mm/Mn	Ms/Mn	Is/In	B3	B14	B3
size	kW	rpm	A		%	Nm				kW	rpm	A		%	Nm				Kgm^2	Kgm^2	Kg
EM48S	0,37	2600	2,79	0,96	60	1,36	0,7	2,4	12,5	0,30	2620	2,42	0,9	60	1,09	0,7	2,5	10-12,5	0,00050	0,00026	6
EM48S	0,55	2700	4,09	0,9	65	1,95	0,6	2,5	16	0,37	2800	2,87	0,8	70	1,26	0,9	3,5	14-16	0,00056	0,00032	8,6
EM48M	0,75	2750	5,12	0,98	65	2,6	0,5	3	20	0,55	2850	4,09	0,9	65	1,84	0,7	3,7	16-20	0,00067	0,00042	9
EM48M	1,1	2700	7,40	0,95	68	3,89	0,35	2,7	20	0,75	2800	5,18	0,9	70	2,56	0,5	3,8	16-20	0,00077	0,00052	9,5
EM60S	0,75	2730	5,29	0,92	67	2,62	0,65	2,4	25	0,55	2800	4,03	0,9	66	1,88	0,9	3,3	25	0,00140	0,00063	12,5
EM60M	1,1	2720	8,05	0,9	66	3,86	0,6	2,6	30	0,75	2800	5,70	0,88	65	2,56	0,9	3,7	30	0,00152	0,00076	14,5
EM60M	1,5	2700	11,40	0,88	65	5,31	0,6	2,8	35	1,1	2750	8,79	0,85	64	3,82	0,8	3,6	35	0,00165	0,00088	16
EM60L	1,8	2700	13,47	0,88	66	6,37	0,6	2,8	40	1,5	2750	11,80	0,85	65	5,21	0,74	3,2	40	0,00177	0,00100	17,5
EM63S	1,1	2800	7,09	0,9	75	3,75	0,4	2,8	25	0,75	2900	5,82	0,8	70	2,47	0,6	3,4	20-25	0,00166	0,00089	11,2
EM63L	1,5	2800	9,61	0,93	73	5,12	0,5	3,8	30	1,1	2900	7,81	0,85	72	3,62	0,7	4,7	25-30	0,00188	0,00111	12,4
EM63L	1,85	2800	11,92	0,9	75	6,31	0,5	3,5	35	1,5	2850	10,51	0,85	73	5,03	0,6	4,1	30-35	0,00208	0,00131	14,1
EM63L	2,2	2830	12,61	0,96	79	7,42	0,4	4,6	45	1,85	2850	10,72	0,95	79	6,20	0,5	5,4	40-45	0,00238	0,00161	16
EM80S	1,5	2800	9,93	0,9	73	5,12	0,6	4,1	45	1,1	2850	8,54	0,8	70	3,69	0,6	4,8	40-45	0,00702	0,00183	22
EM80S	2,2	2750	13,15	0,97	75	7,64	0,6	3,7	55	1,85	2800	11,02	0,96	76	6,31	0,6	4,4	50-55	0,00734	0,00215	24,5
EM80S	3	2800	17,75	0,98	75	10,23	0,3	4,2	55	2,2	2850	12,98	0,97	76	7,37	0,3	4,9	50-55	0,00776	0,00257	27,5

Dimensions E48 - B3

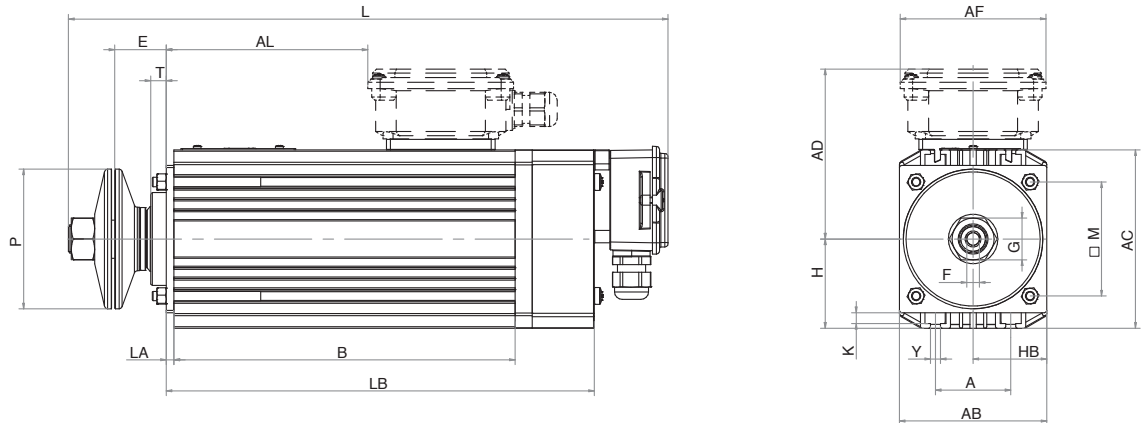
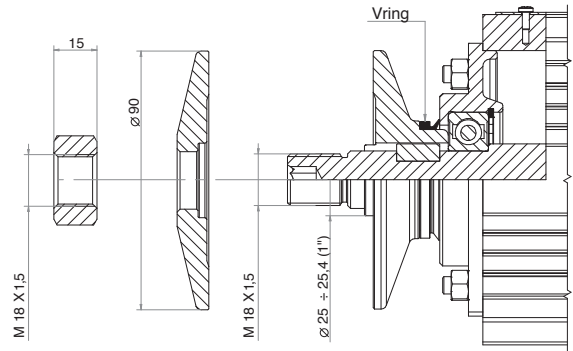

ET

Size	A	AB	AC	B	E	F	G	H	HB	L	LB	K	Y	M	P	T	AD	AF	AL	LA	AP
ET48S	48	95	115	150	33	8	27	57,5	47,5	316	206	7	6	73,5	90	10	109	94	60	5	///
ET48M	48	95	115	200	33	8	27	57,5	47,5	366	256	7	6	73,5	90	10	109	94	110	5	///
ET48La	48	95	115	220	33	8	27	57,5	47,5	386	276	7	6	73,5	90	10	109	94	130	5	///
ET48Lb	48	95	115	255	33	8	27	57,5	47,5	421	311	7	6	73,5	90	10	109	94	165	5	///

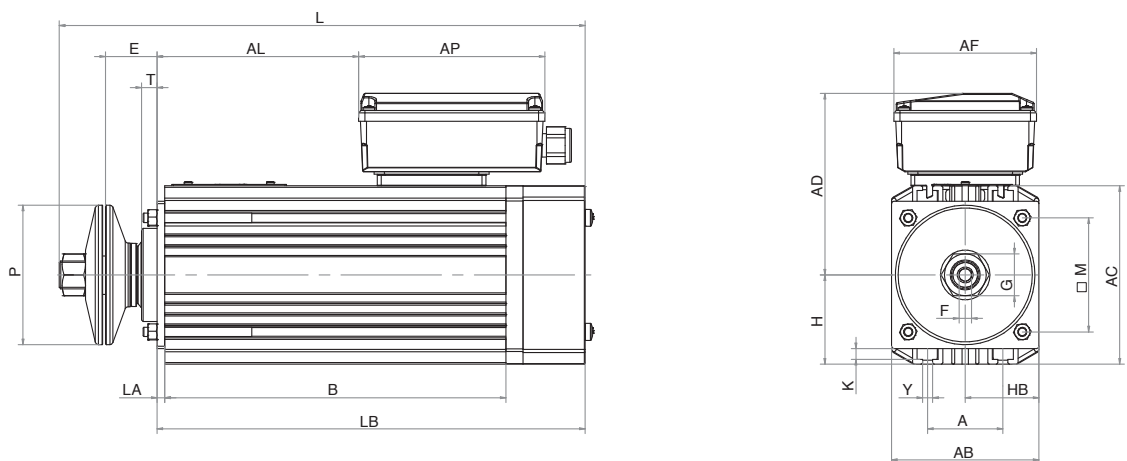

EM

Size	A	AB	AC	B	E	F	G	H	HB	L	LB	K	Y	M	P	T	AD	AF	AL	LA	AP
EM48S	48	95	115	150	33	8	27	57,5	47,5	269	236	7	6	73,5	90	10	117	92	60	5	120
EM48M	48	95	115	200	33	8	27	57,5	47,5	319	256	7	6	73,5	90	10	117	92	110	5	120

Dimensions E48 - B14

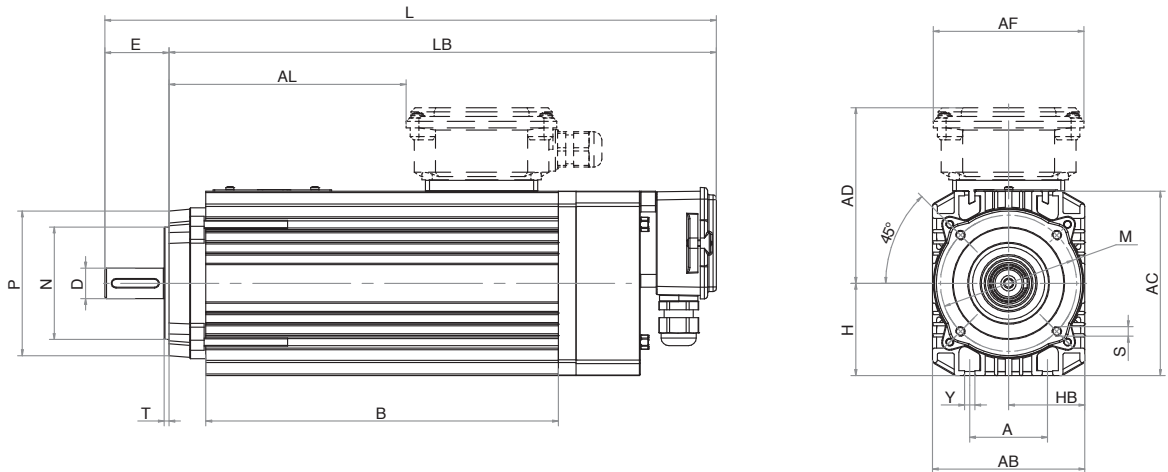
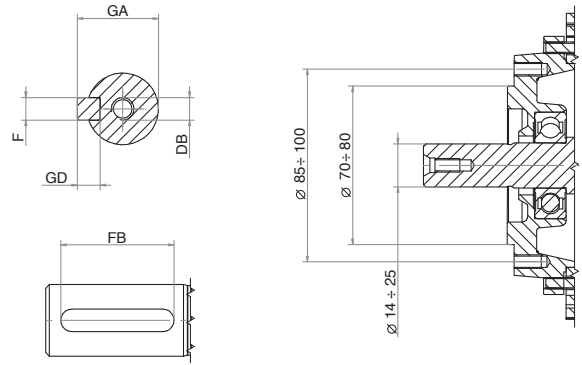

ET

Size	A	AB	AC	B	H	HB	L	LB	Y	P*	N*	M*	T	S	D	E	F	FB	GA	GD	AD	AF	AL	DB	AP
ET48S	48	95	115	150	57,5	47,5	316	206	6	90	70	73,5	3	M6	14	30	5	20	16,5	5	109	94	78	M5	///
ET48M	48	95	115	200	57,5	47,5	366	256	6	90	70	73,5	3	M6	14	30	5	20	16,5	5	109	94	128	M5	///
ET48La	48	95	115	220	57,5	47,5	381	341	6	95x115	80	73,5	3	M6	19	40	6	30	21,5	6	109	94	148	M6	///
ET48Lb	48	95	115	255	57,5	47,5	421	311	6	95x115	80	73,5	3	M6	19	40	6	30	21,5	6	109	94	183	M6	///

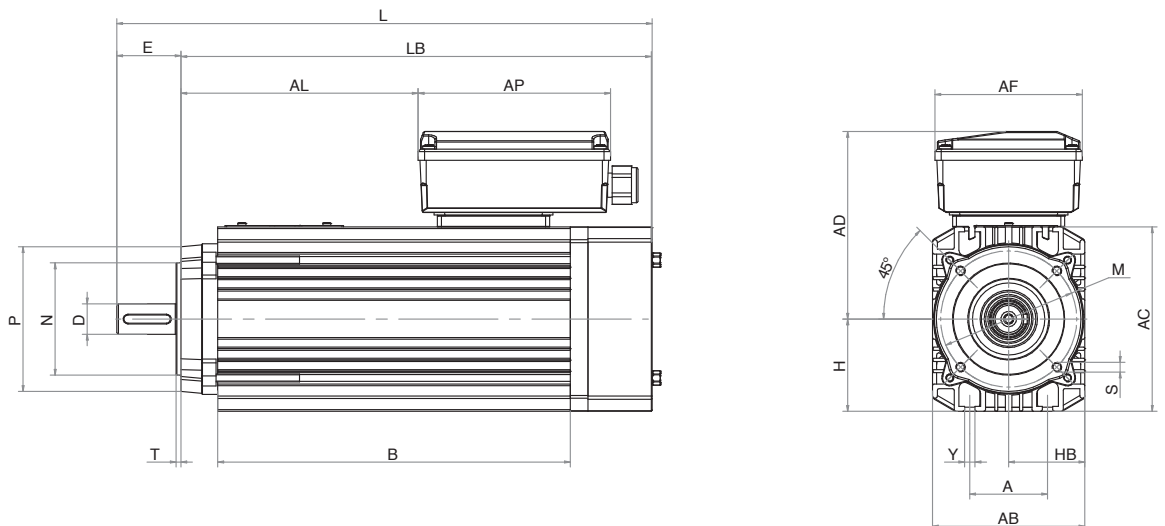

EM

Size	A	AB	AC	B	H	HB	L	LB	Y	P*	N*	M*	T	S	D	E	F	FB	GA	GD	AD	AF	AL	DB	AP
EM48S	48	95	115	150	57,5	47,5	264	223	6	90	70	73,5	3	M6	14	30	5	20	16,5	5	117	92	78	M5	120
EM48M	48	95	115	200	57,5	47,5	314	273	6	90	70	73,5	3	M6	14	30	5	20	16,5	5	117	92	128	M5	120

*Flange IEC 63 available on demand.
P= Ø90 N= Ø60 M= Ø75

Dimensions

E60 - B3

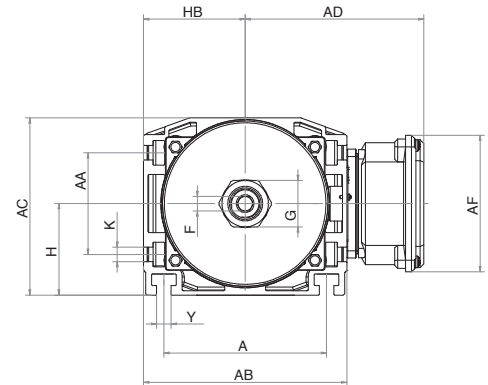
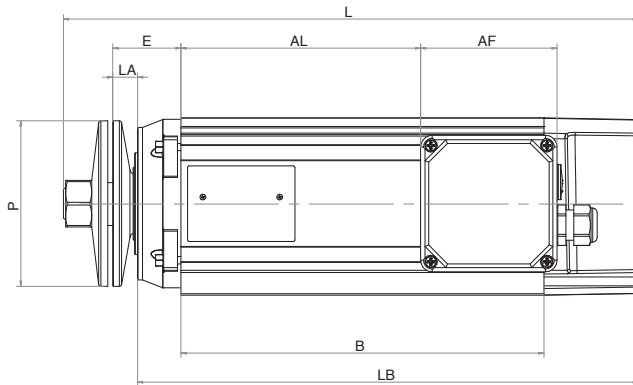
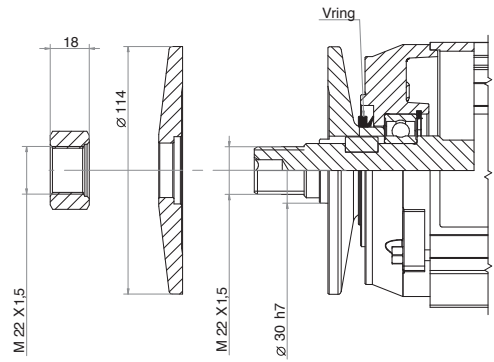

ET

size	A	AB	AC	AA	B	E	F	G	H	HB	L	LB	K	Y	P	AD	AF	AL	LA	AP
ET60S	112	140	122	70	170	47	10	32	63	70	316	265	10	10	114	123	94	85	17	///
ET60M	112	140	122	70	210	47	10	32	63	70	356	305	10	10	114	123	94	125	17	///
ET60L	112	140	122	70	250	47	10	32	63	70	396	345	10	10	114	123	94	165	17	///

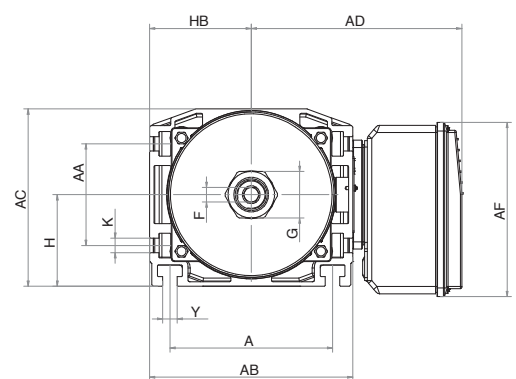
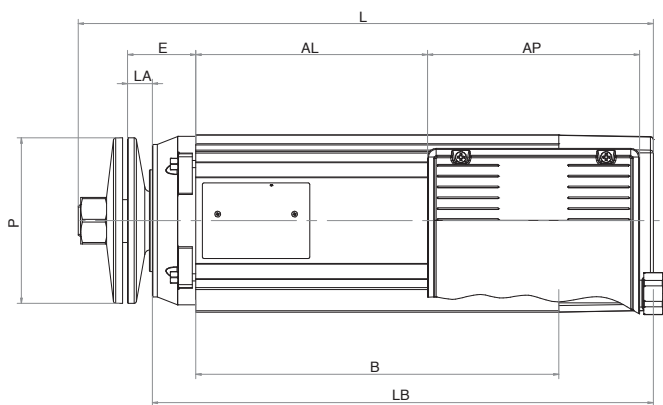

EM

size	A	AB	AC	AA	B	E	F	G	H	HB	L	LB	K	Y	P	AD	AF	AL	LA	AP
EM60S	112	140	122	70	170	47	10	32	63	70	316	265	10	10	114	145	120	79	17	146
EM60M	112	140	122	70	210	47	10	32	63	70	356	305	10	10	114	145	120	119	17	146
EM60L	112	140	122	70	250	47	10	32	63	70	396	345	10	10	114	145	120	159	17	146

Dimensions E60 - B14

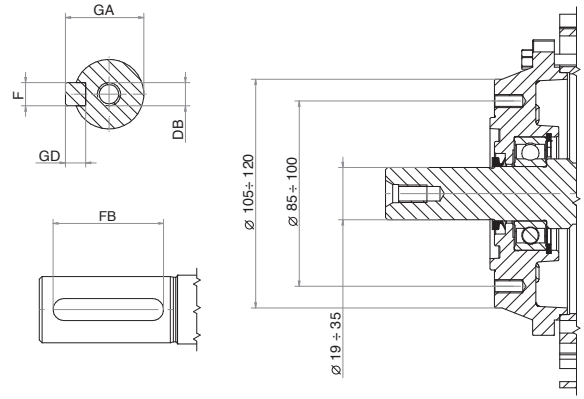

ET

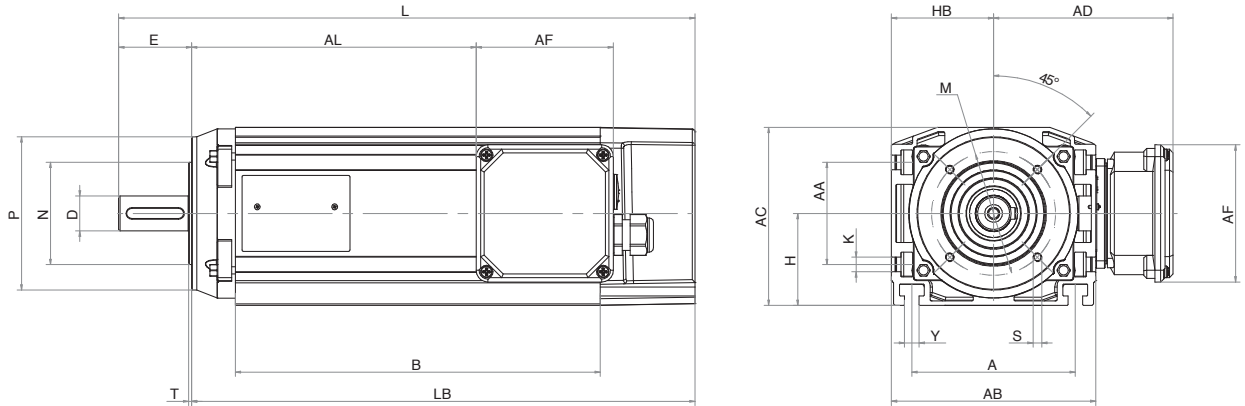

size	A	AB	AC	AA	B	L	LB	Y	K	P*	N*	M*	T	S	D	E	F	FB	GA	GD	AD	AF	AL	DB	AP
ET60S	112	140	122	70	170	315	265	10	10	105	70	85	3	M6	19	40	6	30	21,5	6	123	94	105	M6	▮
ET60M	112	140	122	70	210	355	305	10	10	105	70	85	3	M6	19	40	6	30	21,5	6	123	94	155	M6	▮
ET60L	112	140	122	70	250	395	345	10	10	105	70	85	3	M6	24	50	8	40	27	7	123	94	195	M8	▮

EM

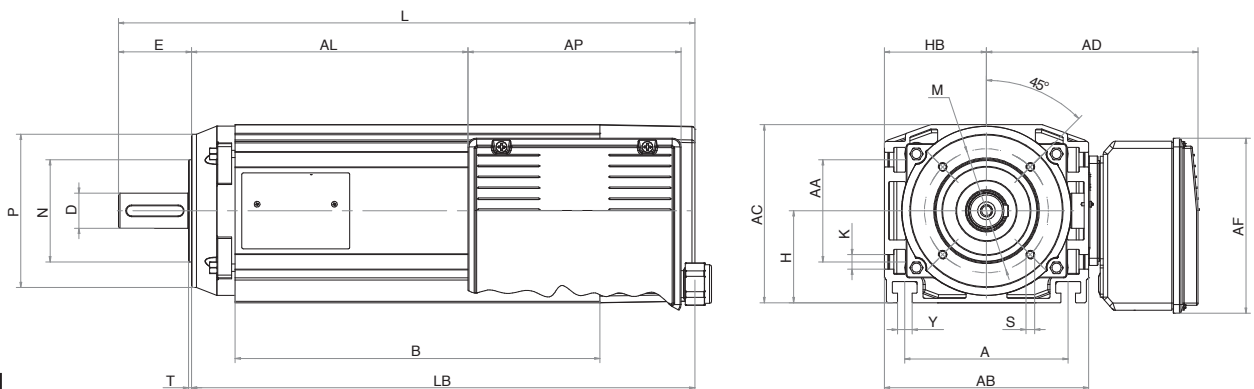

size	A	AB	AC	AA	B	L	LB	Y	K	P*	N*	M*	T	S	D	E	F	FB	GA	GD	AD	AF	AL	DB	AP
EM60S	112	140	122	70	170	315	265	10	10	105	70	85	3	M6	19	40	6	30	21,5	6	145	120	109	M6	146
EM60M	112	140	122	70	210	355	305	10	10	105	70	85	3	M6	19	40	6	30	22	6	145	120	149	M6	146
EM60L	112	140	122	70	250	395	345	10	10	105	70	85	3	M6	24	50	8	40	27	7	145	120	189	M8	146

*Flange IEC 80 available on demand.
P= Ø120 N= Ø80 M= Ø100

Dimensions E63 - B3

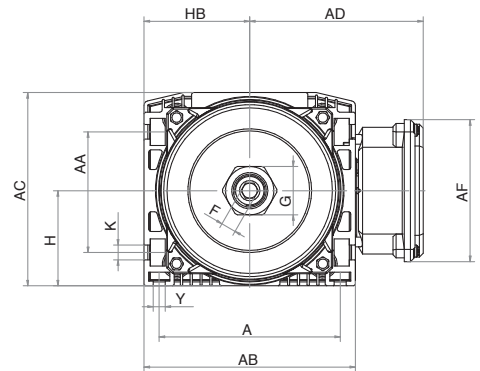
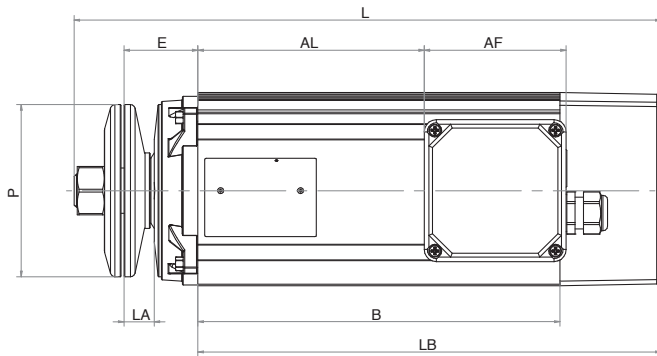
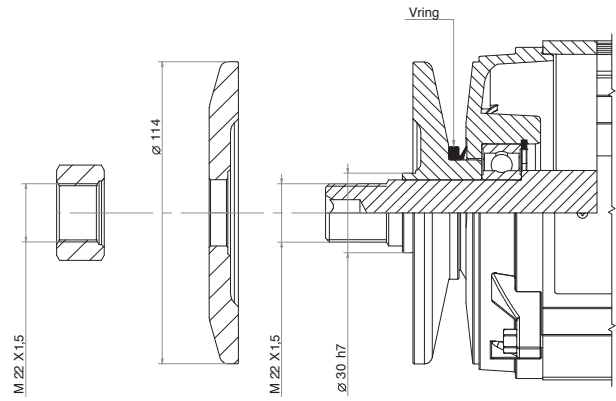

ET

size	A	AB	AC	AA	B	E	F	G	H	HB	L	LB	K	Y	P	AD	AF	AL	LA	AP
ET63S	120	140	128	80	180	49	10	32	63	70	329	247	10	8	114	115	94	90	20	///
ET63La	120	140	128	80	240	49	10	32	63	70	389	307	10	8	114	115	94	150	20	///
ET63Lb	120	140	128	80	260	49	10	32	63	70	409	327	10	8	114	115	94	170	20	///

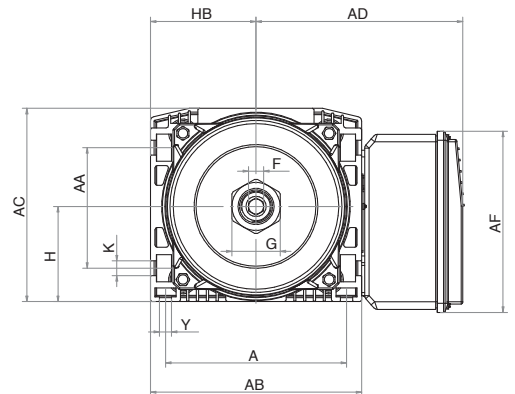
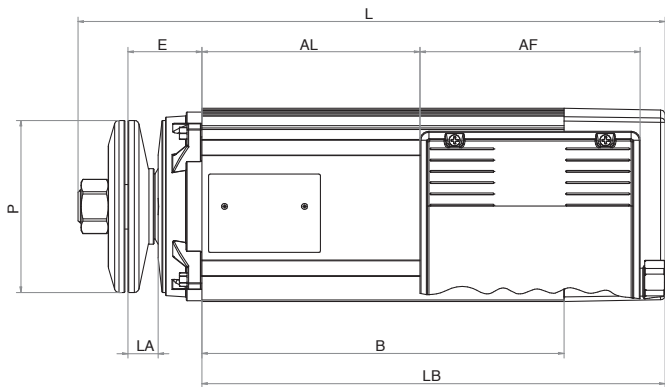

EM

size	A	AB	AC	AA	B	E	F	G	H	HB	L	LB	K	Y	P	AD	AF	AL	LA	AP
EM63S	102	140	128	80	180	49	10	32	63	70	329	247	10	8	114	137	120	84	20	146
EM63L	102	140	128	80	240	49	10	32	63	70	389	307	10	8	114	137	120	144	20	146

Dimensions E63 - B14

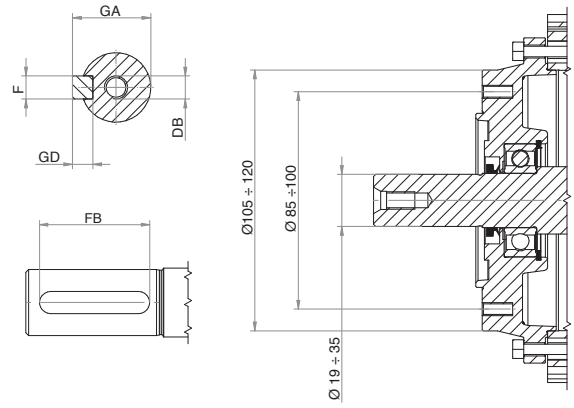

ET

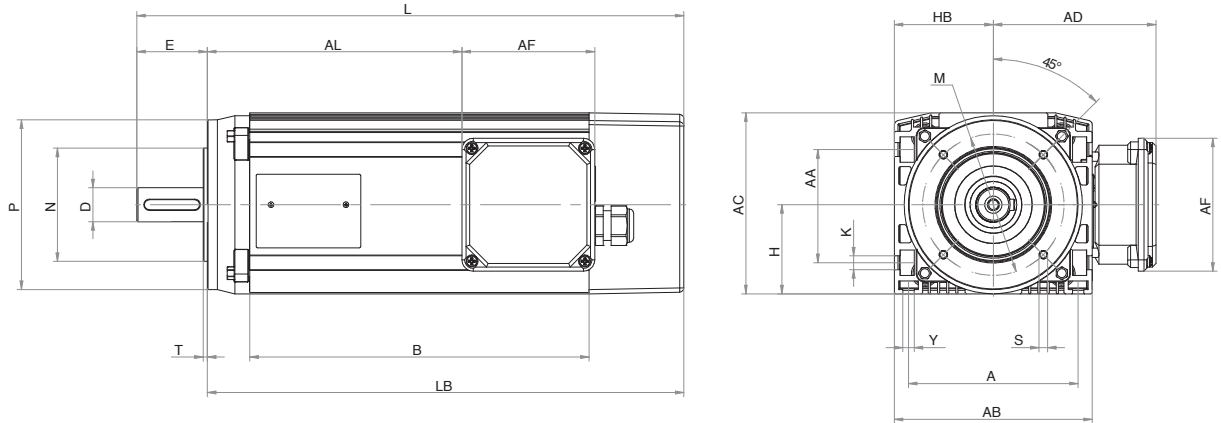

size	A	AB	AC	AA	B	L	LB	Y	K	P*	N*	M*	T	S	D	E	F	FB	GA	GD	AD	AF	AL	DB	AP
ET63S	120	140	128	80	180	327	277	8	10	120	80	100	3	M6	19	40	6	30	21,5	6	115	94	120	M6	∕
ET63La	120	140	128	80	240	387	337	8	10	120	80	100	3	M6	24	50	8	40	27	7	115	94	180	M8	∕
ET63Lb	120	140	128	80	260	407	357	8	10	120	80	100	3	M6	24	50	8	40	27	7	115	94	200	M8	∕

EM

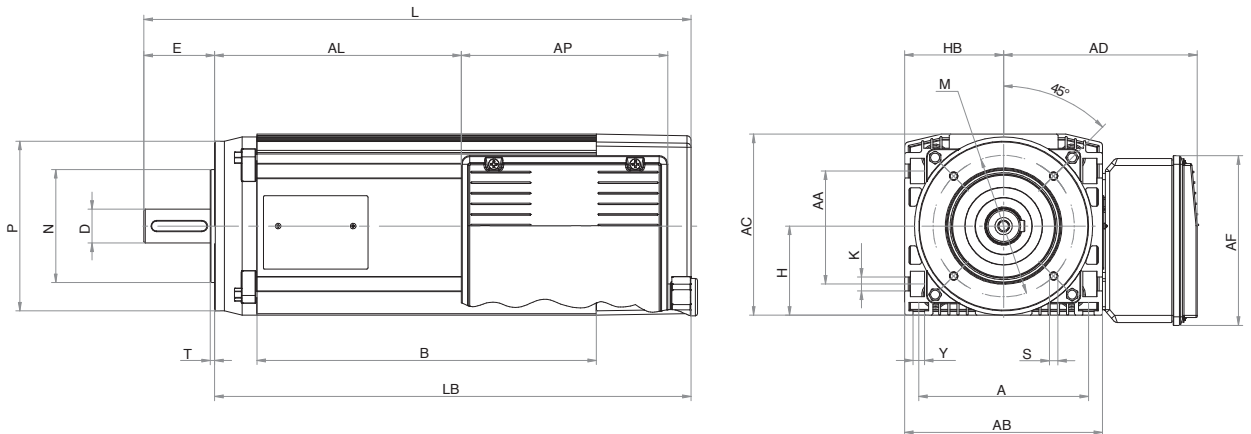

size	A	AB	AC	AA	B	L	LB	Y	K	P*	N*	M*	T	S	D	E	F	FB	GA	GD	AD	AF	AL	DB	AP
EM63S	120	140	128	80	180	327	277	8	10	120	80	100	3	M6	19	40	6	30	21,5	6	137	120	114	M6	146
EM63L	120	140	128	80	240	387	337	8	10	120	80	100	3	M6	24	50	8	40	27	7	137	120	174	M8	146

*Flange IEC 80 available on demand.
P= Ø120 N= Ø80 M= Ø100

Dimensions E80 - B3

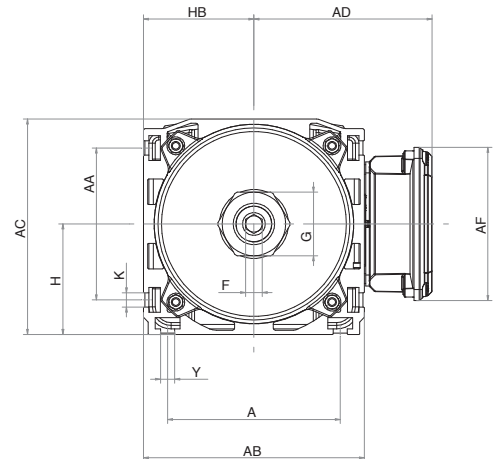
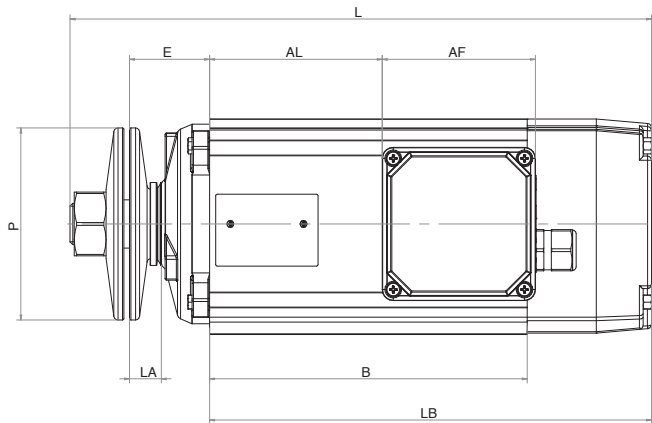
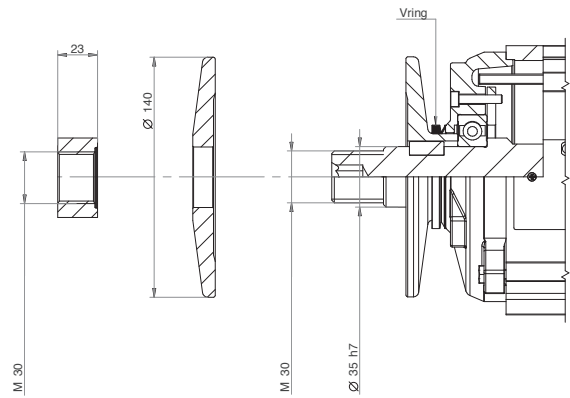

ET

size	A	AB	AC	AA	B	E	F	G	H	HB	L	LB	K	Y	P	AD	AF	AL	LA	AP
ET80S	125	160	156	110	230	58	12	46	80	80	421	320	10	10	139	129	111	125	23	///
ET80M	125	160	156	110	280	58	12	46	80	80	471	370	10	10	139	129	111	175	23	///
ET80La	125	160	156	110	350	58	12	46	80	80	541	440	10	10	139	129	111	245	23	///
ET80Lb	125	160	156	110	400	58	12	46	80	80	591	490	10	10	139	129	111	295	23	///

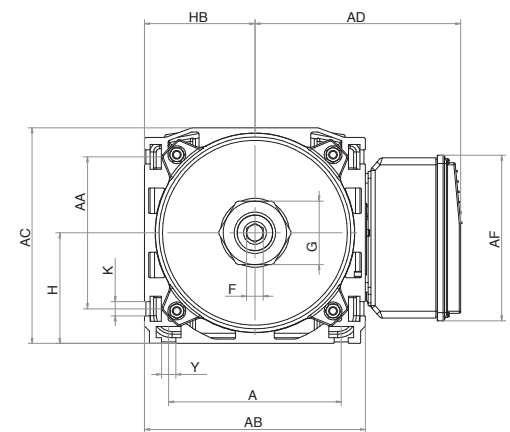
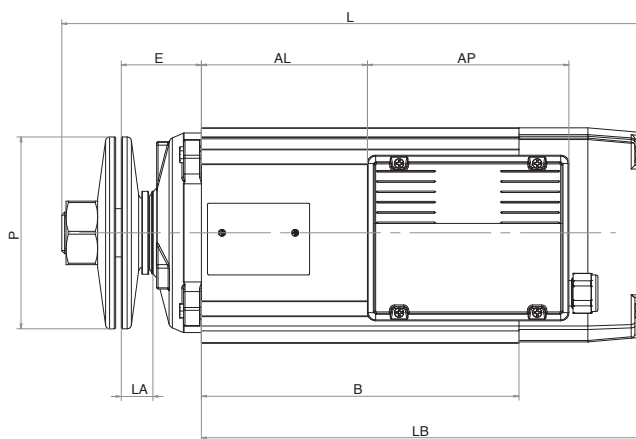

EM

size	A	AB	AC	AA	B	E	F	G	H	HB	L	LB	K	Y	P	AD	AF	AL	LA	AP
EM80S	125	160	156	110	230	58	12	46	80	80	421	320	10	10	139	149	120	120	23	146

Dimensions E80 - B14

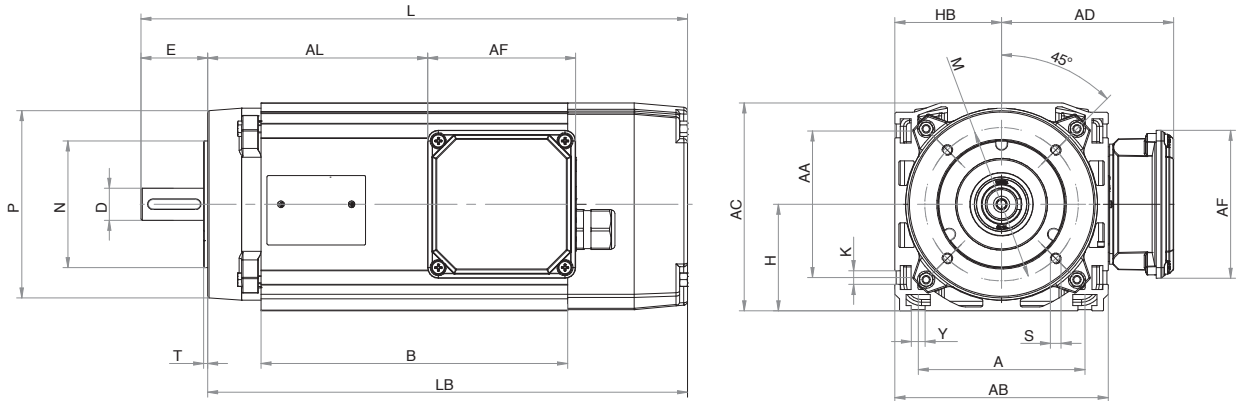
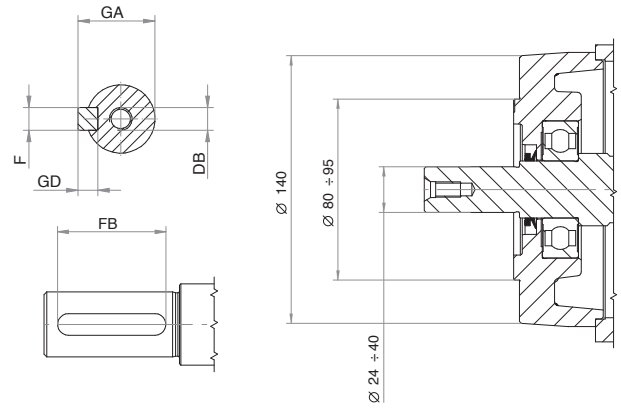

ET

size	A	AB	AC	AA	B	L	LB	Y	K	P*	N*	M*	T	S	D	E	F	FB	GA	GD	AD	AF	AL	DB	AP
ET80S	125	160	156	110	230	410	360	10	10	140	95	115	3	M8	24	50	8	40	27	7	129	111	165	M8	/
ET80M	125	160	156	110	280	470	410	10	10	140	95	115	3	M8	28	60	8	50	27	7	129	111	215	M10	/
ET80La	125	160	156	110	350	540	480	10	10	140	95	115	3	M8	28	60	8	50	27	7	129	111	285	M10	/
ET80Lb	125	160	156	110	400	590	530	10	10	140	95	115	3	M8	28	60	8	50	27	7	129	111	335	M10	/

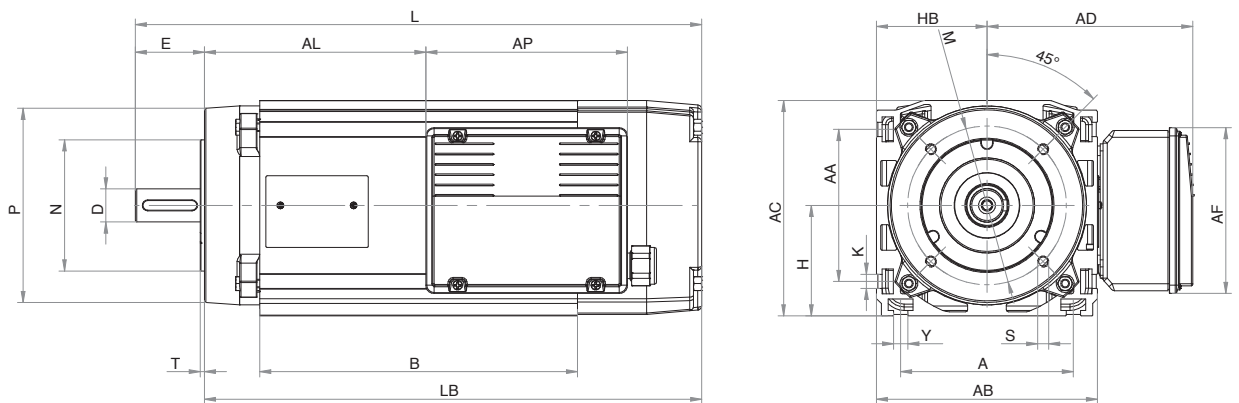

EM

size	A	AB	AC	AA	B	L	LB	Y	K	P*	N*	M*	T	S	D	E	F	FB	GA	GD	AD	AF	AL	DB	AP
EM80S	125	160	156	110	230	410	360	10	10	140	95	115	3	M8	28	60	8	50	27	7	149	120	160	M8	146

*Flange IEC 80 available on demand.
P= Ø120 N= Ø80 M= Ø100

Terminal Box Position

E48

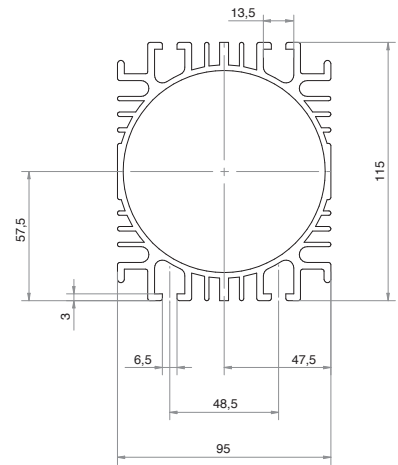
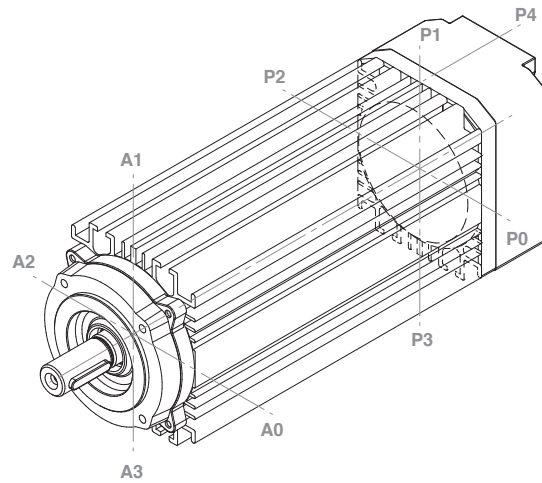

Sign	Description		
A	A0	BS VS/AL	top shaft side
	A1	DX VS/AL	right shaft side
	A2	BS VS/AL	top shaft side
	A3	DX VS/AL	right shaft side
FRONT	P0	BS VS/VN	top fan side
	P1	DX VS/VN	right fan side
	P2	BS VS/VN	top fan side
P	P3	DX VS/VN	right fan side
	P4	CV	back on fan cover
BACK			

E60

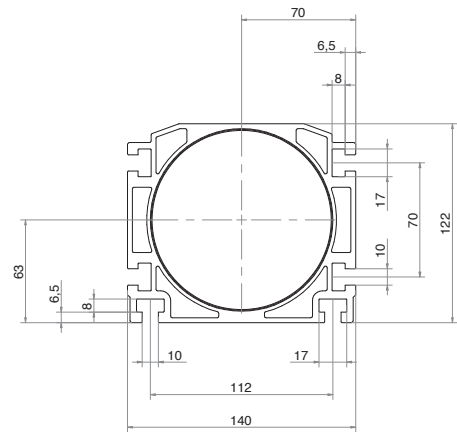
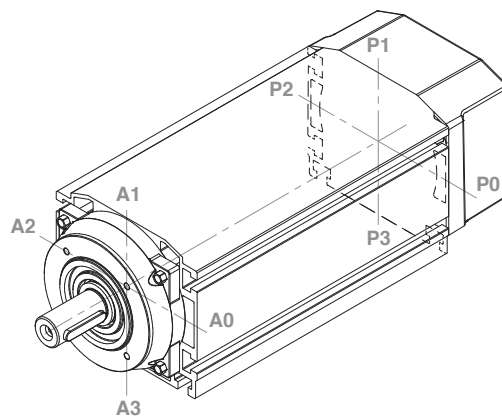

Sign	Description		
A	A0	DX VS/AL	right shaft side
	A1	BS VS/AL	top shaft side
	A2	SX VS/AL	left shaft side
	A3	BI VS/AL	down shaft side
FRONT	P0	DX VS/VN	right fan side
	P1	BS VS/VN	top fan side
P	P2	SX VS/VN	left fan side
	P3	BI VS/VN	down fan side
BACK			

Terminal Box Position

E63

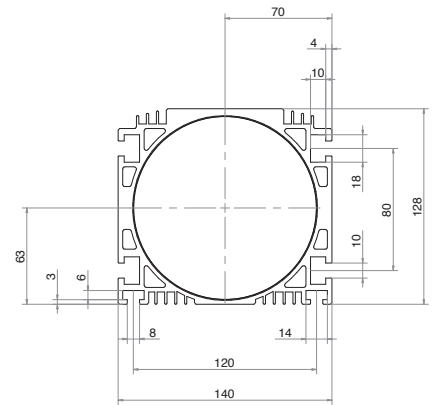
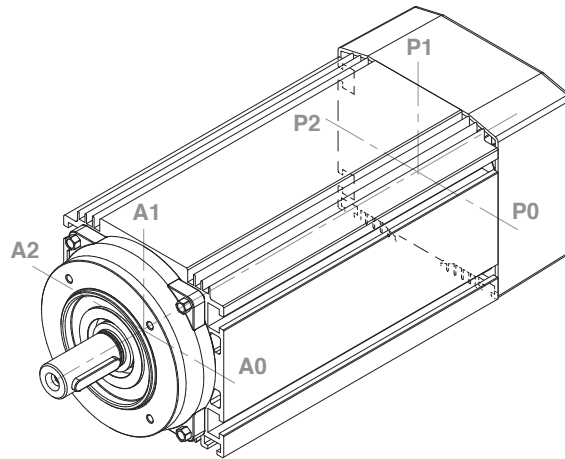

Sign	Description		
A	A0	DX VS/AL	right shaft side
	A1	BS VS/AL	top shaft side
	A2	SX VS/AL	left shaft side
P	P0	DX VS/VN	right fan side
	P1	BS VS/VN	top fan side
BACK	P2	SX VS/VN	left fan side

E80

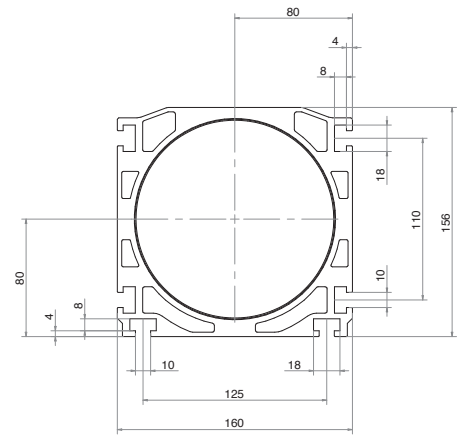
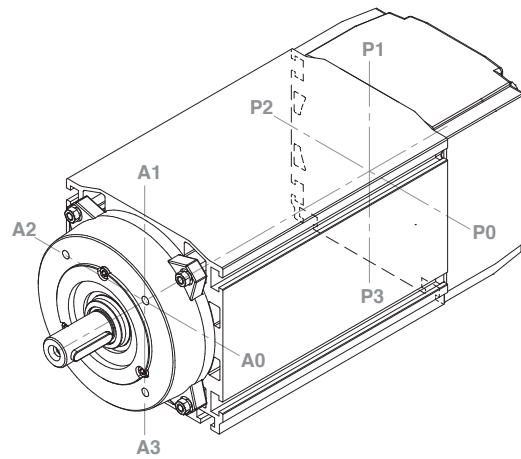

Sign	Description		
A	A0	DX VS/AL	right shaft side
	A1	BS VS/AL	top shaft side
	A2	SX VS/AL	left shaft side
	A3	BI VS/AL	down shaft side
P	P0	DX VS/VN	right fan side
	P1	BS VS/VN	top fan side
	P2	SX VS/VN	left fan side
BACK	P3	BI VS/VN	down fan side

Brake Option

Low Center Motors can be equipped with a Direct Current Brake (FPC). Brake motor external sizes are equal to those of the corresponding standard motors (see pages 6-13). This brake is particularly suitable for applications where progressive braking is required. Without any power applied, the shaft is locked in compliance with all existing safety laws and standards.

The direct current brake is a single friction face brake with maximum reduced noise level and maximum safety standards. The brake works because of the force exerted by the springs. By taking the electromagnet-supply off, the mobile anchor, pushed by the springs, presses the friction pad against the iron fan. By supplying the electromagnet coil the brake is released through the rectifier.

Air-gap adjusting, at the nominal value of supply voltage, is made during the assembly. During the operation this value has to be restored due to wear of the friction gasket. Such wear depends on the use. The air gap can be reset by simply tightening up the back locking nuts until you get the value shown on the following chart. The screw can be tightened without removing the fan cover.

NOTE: the following information is required when an order is placed: 1) supply voltage of the brake, 2) application data, 3) moment of inertia: 4) duty cycle (number of operations): 5) brake connections (terminal block or separate from the motor-supply). Upon request, special rectifiers are available with an EMC filter to reduce the braking delay.

STANDARD FEATURES

brake rated voltage	230V (Pn ≤ 3 kW)
	400V (Pn > 3 kW)
protection rating	IP54

size	break torque	engagine time	release time	tempo rilascio	braking gap
	Nm	W	ms	ms	mm
E60	4	18	40	100	0,2
E63	4	18	40	100	0,2
E80	9	25	60	150	0,2

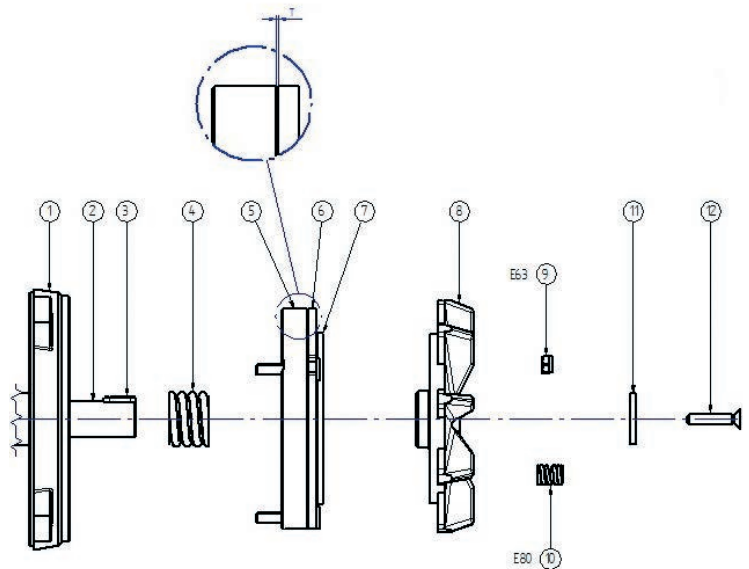

1	FPC end shield	7	friction pad
2	shaft	8	cooling fan (cast iron)
3	key	9	nyuloc nut
4	spring	10	spring unscrewing
5	brake coil	11	washer
6	mobile anchor	12	adjustment screw

Electric Data

ETFPC	S6 - 60%									S1									J		W		max e		
	2 POLES		Pn	n	In (400V)	cosφ	η	Mn	Mm Mn	Ms Mn	Is In	Pn	n	In (400V)	cosφ	η	Mn	Mm Mn	Ms Mn	Is In	B3	B14		B3	bt
size	kW	rpm	A		%	Nm					kW	rpm	A		%	Nm					Kgm^2	Kgm^2	Kg	Nm	J
ET60S	1,5	2750	3,35	0,85	76	5,21	2,3	2,1	4,5	1,1	2800	2,54	0,8	78	3,75	3,2	2,9	5,9	0,00202	0,00126	16	4	2000		
ET60M	1,8	2790	3,96	0,87	76	6,33	2,4	2,2	4,9	1,5	2835	3,39	0,82	78	5,05	3	2,8	5,7	0,00215	0,00138	17	4	2000		
ET60M	2,2	2800	4,80	0,86	77	7,5	2,7	2,7	6,2	1,85	2840	4,12	0,83	78	6,22	3,2	3,2	7,2	0,00227	0,00150	17,5	4	2000		
ET60L	3	2825	6,70	0,82	79	10,1	3,1	3,1	5,7	2,2	2880	5,51	0,72	80	7,29	4,3	4,3	6,9	0,00252	0,00175	20	4	2000		
ET63S	1,1	2740	2,52	0,83	76	3,83	2,3	2,3	4,7	0,75	2840	1,85	0,76	77	2,52	3,6	3,6	6,5	0,00206	0,00129	12,5	4	2000		
ET63S	1,5	2700	3,40	0,85	75	5,31	2,6	2,5	4,3	1,1	2800	2,48	0,8	80	3,75	3,7	3,5	5,9	0,00216	0,00139	13,8	4	2000		
ET63S	1,85	2750	4,19	0,85	75	6,42	3	3	4,5	1,5	2800	3,43	0,83	76	5,12	3,8	3,8	5,5	0,00236	0,00159	16,5	4	2000		
ET63S	2,2	2800	4,67	0,84	81	7,5	3	3	5,7	1,85	2800	4,07	0,8	82	6,2	3,6	3,6	6,5	0,00256	0,00179	17	4	2000		
ET63La	2,2	2800	4,67	0,84	81	7,5	3	3	5,7	1,85	2830	4,07	0,8	82	6,2	3,6	3,6	6,5	0,00258	0,00181	17,5	4	2000		
ET63La	3	2800	6,36	0,84	81	10,2	3,2	3,2	6	2,2	2850	4,96	0,78	82	7,37	4,4	4,4	7,7	0,00288	0,00211	19,5	4	2000		
ET63Lb	3,7	2760	7,67	0,87	80	12,8	3	2,7	5,9	3	2820	6,36	0,83	82	10,2	3,7	3,4	7,2	0,00317	0,00240	21,5	4	2000		
ET63Lb	4,4	2730	8,30	0,88	79	14	2,7	2,5	5,5	3	2820	6,36	0,83	82	10,2	3,7	3,4	7,2	0,00317	0,00240	21,5	4	2000		
ET80S	3	2850	6,44	0,83	81	10,1	3,2	3,2	6	2,2	2900	5,16	0,76	81	7,24	4,4	4,4	7,5	0,00860	0,00341	30	12	3000		
ET80S	4	2890	8,80	0,8	82	13,2	3,3	3,3	6,8	3	2920	7,45	0,7	83	9,81	4,4	4,4	8	0,00886	0,00367	30,5	12	3000		
ET80M	5,5	2880	11,70	0,8	85	18,2	3,6	3,5	6,8	4	2920	9,60	0,7	86	13,1	5	4,9	8,3	0,00938	0,00432	34,5	12	3000		
ET80La	7,5	2850	15,20	0,85	84	25,1	3,3	3,3	7,6	5,5	2900	11,80	0,79	85	18,1	4,6	4,6	9,7	0,01055	0,00549	42,8	12	3000		

•S6 - 40%

ETFPC	S6 - 60%									S1									J		W		max e		
	4 POLES		Pn	n	In (400V)	cosφ	η	Mn	Mm Mn	Ms Mn	Is In	Pn	n	In (400V)	cosφ	η	Mn	Mm Mn	Ms Mn	Is In	B3	B14		B3	bt
size	kW	rpm	A		%	Nm					kW	rpm	A		%	Nm					Kgm^2	Kgm^2	Kg	Nm	J
ET60S	1,1	1370	2,94	0,75	72	7,67	2,7	2,7	4,4	0,75	1420	2,18	0,7	71	5,04	2,7	2,7	4,9	0,00333	0,00223	14,5	4	2000		
ET60L	1,5	1380	4,18	0,7	74	10,4	2,6	2,6	4,5	1,1	1410	3,35	0,65	73	7,45	3,6	3,6	5,6	0,00329	0,00253	17,5	4	2000		
ET60L	1,8	1390	4,95	0,7	75	12,4	2,5	2,5	4,6	1,5	1400	4,50	0,65	74	10,20	3	3	5,1	0,00368	0,00292	20,5	4	2000		
ET63S	0,75	1380	2,03	0,72	74	5,19	2,1	2	3,5	0,55	1400	1,68	0,62	76	3,75	2,9	2,8	4,2	0,00267	0,00190	13,7	4	2000		
ET63S	1,1	1385	2,71	0,77	76	7,58	2,4	2,3	4	0,75	1440	2,17	0,64	78	4,97	3,6	3,5	5	0,00300	0,00223	14,6	4	2000		
ET63La	1,5	1300	3,86	0,79	71	11	1,8	1,8	3,2	1,1	1360	2,90	0,71	77	7,72	2,6	2,6	4,3	0,00334	0,00257	16,6	4	2000		
ET63La	1,85	1320	4,63	0,78	74	13,4	2,2	2,2	4,1	1,5	1360	3,90	0,73	76	10,50	2,8	2,8	4,9	0,00383	0,00306	17,0	4	2000		
ET80S	2,2	1400	4,96	0,8	80	15	3	2,7	5	1,85	1420	4,40	0,75	81	12,40	3,6	3,3	5,6	0,01122	0,00604	31,0	12	3000		
ET80M	3	1370	6,77	0,8	80	20,9	2,2	2,2	4,4	2,2	1400	5,23	0,75	81	15,00	3,1	3,1	5,7	0,01128	0,00622	32,5	12	3000		

EMFPC	S6 - 60%									S1									J		W		max e		
	2 POLES		Pn	n	In (230V)	cosφ	η	Mn	Ms Mn	Is In	Cm	Pn	n	In (230V)	cosφ	η	Mn	Ms Mn	Is In	Cm	B3	B14		B3	bt
Size	kW	rpm	A		%	Nm				uF	kW	rpm	A		%	Nm				uF	Kgm^2	Kgm^2	Kg	Nm	J
EM60S	0,75	2730	5,29	0,92	67	2,62	0,65	2,4	25	0,55	2800	4,03	0,9	66	1,88	0,9	3,3	25	0,00190	0,00113	14,5	4	2000		
EM60M	1,1	2720	8,05	0,9	66	3,86	0,6	2,6	30	0,75	2800	5,70	0,88	65	2,56	0,9	3,7	30	0,00202	0,00126	16,5	4	2000		
EM60M	1,5	2700	11,40	0,88	65	5,31	0,6	2,8	35	1,1	2750	8,79	0,85	64	3,82	0,8	3,6	35	0,00215	0,00138	18,0	4	2000		
EM60L	1,8	2700	13,47	0,88	66	6,37	0,6	2,8	40	1,5	2750	11,80	0,85	65	5,21	0,74	3,2	40	0,00227	0,00150	19,5	4	2000		
EM63S	1,1	2800	7,09	0,9	75	3,75	0,4	2,8	25	0,75	2900	5,82	0,8	70	2,47	0,6	3,4	20-25	0,00216	0,00139	12,2	4	2000		
EM63L	1,5	2800	9,61	0,93	73	5,12	0,5	3,8	30	1,1	2900	7,81	0,85	72	3,62	0,7	4,7	25-30	0,00238	0,00161	14,4	4	2000		
EM63L	1,85	2800	11,92	0,9	75	6,31	0,5	3,5	35	1,5	2850	10,51	0,85	73	5,03	0,6	4,1	30-35	0,00258	0,00181	16,1	4	2000		
EM63L	2,2	2830	12,61	0,96	79	7,42	0,4	4,6	45	1,85	2850	10,72	0,95	79	6,20	0,5	5,4	40-45	0,00288	0,00211	18,0	4	2000		
EM80S	1,5	2800	9,93	0,9	73	5,12	0,6	4,1	45	1,1	2850	8,54	0,8	70	3,69	0,6	4,8	40-45	0,00812	0,00293	24,5	12	3000		
EM80S	2,2	2750	13,15	0,97	75	7,64	0,6	3,7	55	1,85	2800	11,02	0,96	76	6,31	0,6	4,4	50-55	0,00844	0,00325	27,0	12	3000		
EM80S	3	2800	17,75	0,98	75	10,23	0,3	4,2	55	2,2	2850	12,98	0,97	76	7,37	0,3	4,9	50-55	0,00886	0,00367	30,0	12	3000		

Speed Range Inverter Drive

The Low Center Motors are manufactured by means of advanced technology and high quality material. They are suitable for inverter applications.

Using angular contact ball bearings makes the Low Center Motors especially applicable to applications with axial loads and applications that require high speeds.

The nominal torque of a self ventilated motor with inverter is lower at low frequency and at high frequency. It is lower at low frequency for thermal reasons due to fan's lower speed. It is lower at high frequency for electrical reasons due to the de-fluxing.

The diagram below shows the typical torque and nominal power curves. Illustrating how the overheating limits are not exceeded in either a self ventilated motor or fan cooled motor.

Please see "Special Implementation" for further specializations on Low Center Motors with inverters, such as servo-ventilation, thermal probes, etc.

Our Technical Department is available for any questions or details you may require.

NOTE: For brake motors the brake's power supply must be isolated and inverter must be at time of brake engagement.

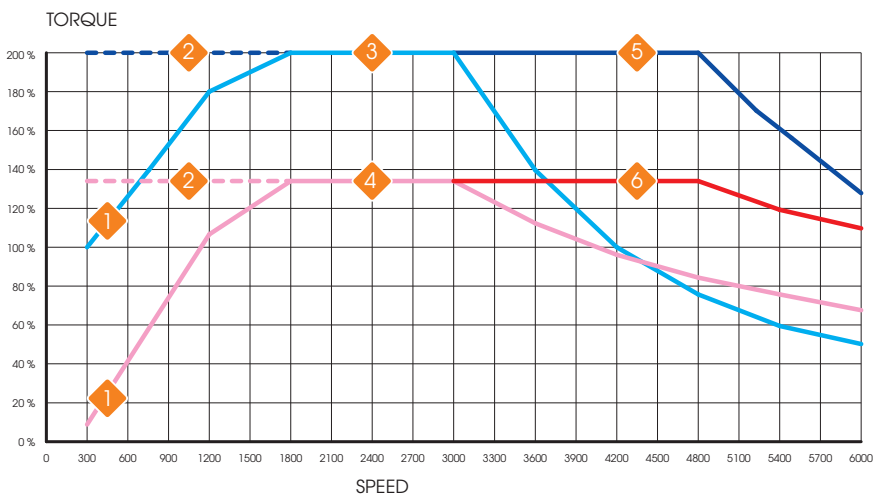

1	continuous duty
2	intermittent duty
3	breakdown torque star connected
4	rated power star connected
5	breakdown torque delta connected
6	rated power delta connected

Electric Data

ETSTD	S1 - 6000 rpm										J		W
2 POLES	Pn	n	n max [©]	In (400V)	cosf	η	Mn	Mm/Mn	Ms/Mn	Is/In	B3	B14	B3
size	kW	rpm	rpm	A		%	Nm				Kgm ²	Kgm ²	Kg
ET48S	0,25	2840	6000	0,78	0,68	68	0,84	3,3	3,3	4,5	0,00050	0,00026	6
ET48S	0,37	2815	6000	1,03	0,75	69	1,26	3,1	3	4,7	0,00050	0,00026	6
ET48S	0,55	2800	6000	1,39	0,77	74	1,88	2,8	2,7	4,4	0,00056	0,00032	7
ET48M	0,75	2800	6000	1,96	0,7	79	2,56	3,8	3,8	5,2	0,00067	0,00042	8,4
ET48M	1,1	2750	6000	2,79	0,76	75	3,82	3,4	3	5,9	0,00077	0,00052	9,7
ET48La	1,3	2750	6000	3,17	0,78	76	4,51	2,8	2,8	4,3	0,00083	0,00059	10
ET48Lb	1,5	2800	6000	4,19	0,68	76	5,116	3,4	3,4	4,1	0,00123	0,00066	10,6
ET60S	1,1	2800	6000	2,54	0,8	78	3,75	3,2	2,9	5,9	0,00152	0,00076	14
ET60M	1,5	2835	6000	3,39	0,82	78	5,05	3	2,8	5,7	0,00165	0,00088	15
ET60M	1,85	2840	6000	4,12	0,83	78	6,22	3,2	3,2	7,2	0,00177	0,00100	15,5
ET60L	2,2	2880	6000	5,51	0,72	80	7,29	4,3	4,3	6,9	0,00202	0,00125	18
ET63S	0,75	2840	6000	1,85	0,76	77	2,52	3,6	3,6	6,5	0,00156	0,00079	10
ET63S	1,1	2800	6000	2,48	0,8	80	3,75	3,7	3,5	5,9	0,00166	0,00089	11,3
ET63S	1,5	2800	6000	3,43	0,83	76	5,12	3,8	3,8	5,5	0,00186	0,00109	14
ET63S	1,85	2800	6000	4,07	0,8	82	6,2	3,6	3,6	6,5	0,00206	0,00129	14,5
ET63La	1,85	2830	6000	4,07	0,8	82	6,2	3,6	3,6	6,5	0,00208	0,00131	15
ET63La	2,2	2850	6000	4,96	0,78	82	7,37	4,4	4,4	7,7	0,00238	0,00161	17
ET63Lb	3	2820	6000	6,36	0,83	82	10,2	3,7	3,4	7,2	0,00267	0,00190	19
ET80S	2,2	2900	6000	5,16	0,76	81	7,24	4,4	4,4	7,5	0,00750	0,00231	27
ET80S	3	2920	6000	7,45	0,7	83	9,81	4,4	4,4	8	0,00776	0,00257	27,5
ET80M	4	2920	6000	9,60	0,7	86	13,1	5	4,9	8,3	0,00828	0,00322	31,5
ET80La	5,5	2900	6000	11,80	0,79	85	18,1	4,6	4,6	9,7	0,00945	0,00439	39,8
ET80Lb	7,5	2930	6000	18,00	0,7	86	24,4	5,2	4,3	8,7	0,01023	0,00521	45
ET80Lb	9,2	2900	6000	19,60	0,8	87	30	4,2	3,5	8	0,01028	0,00521	44
ET80Lc	11	2860	6000	23,90	0,8	83	36,7	4,5	4,2	8,5	0,01217	0,00712	60

ETSTD	S1 - 6000 rpm										J		W
4 POLES	Pn	n	n max [©]	In (400V)	cosf	η	Mn	Mm/Mn	Ms/Mn	Is/In	B3	B14	B3
size	kW	rpm	rpm	A		%	Nm				Kgm ²	Kgm ²	Kg
ET48S	0,19	1400	6000	0,87	0,56	55	1,26	4,6	4,6	3,2	0,00057	0,00033	5,4
ET48S	0,30	1430	6000	1,46	0,48	62	2,00	4,9	4,9	3,7	0,00069	0,00045	7,1
ET48M	0,37	1400	6000	1,62	0,5	66	2,52	4	4	3,3	0,00082	0,00058	9
ET48La	0,55	1380	6000	2,13	0,62	60	3,81	3,2	3,2	3	0,00091	0,00067	9,7
ET60S	0,75	1420	6000	2,18	0,7	71	5,04	2,7	2,7	4,9	0,00283	0,00173	12,5
ET60L	1,1	1410	6000	3,35	0,65	73	7,45	3,6	3,6	5,6	0,00279	0,00203	15,5
ET60L	1,5	1400	6000	4,50	0,65	74	10,20	3	3	5,1	0,00318	0,00242	18,5
ET63S	0,55	1400	6000	1,68	0,62	76	3,75	2,9	2,8	4,2	0,00217	0,00140	11,2
ET63S	0,75	1440	6000	2,17	0,64	78	4,97	3,6	3,5	5	0,00250	0,00173	12,6
ET63La	1,1	1360	6000	2,90	0,71	77	7,72	2,6	2,6	4,3	0,00284	0,00207	14,6
ET63La	1,5	1360	6000	3,90	0,73	76	10,50	2,8	2,8	4,9	0,00333	0,00256	15
ET80S	1,85	1420	6000	4,40	0,75	81	12,40	3,6	3,3	5,6	0,01012	0,00494	28,5
ET80M	2,2	1400	6000	5,23	0,75	81	15,00	3,1	3,1	5,7	0,01018	0,00512	30

© n max: maximum allowed speed with standard bearings. On Demand specific bearing are available for much higher speed.

Special Executions

UL-CSA Certification

UL products for USA market are identify by file no E176350.
CSA products for CA market are identify by file no LR109925-1.

ATEX

The products can be self certify according to categories ATEX 3GD, area 2 – 22

Voltage / Special frequency

The winding is developed according to the voltage/frequency of the network and the application / inverter's set-up.

Insulated Phases

Special winding, recommended for inverter use.

Class H insulation

Winding insulation increase of 20°C the maximum temperature, compared to F class.

Double impregnation

The double impregnation better compact coil windings improving the electrical protection and permitting an high thermal dissipation. In addition it protects from humidity and corrosion.

Rotor with shaft balancing's degree

Shaft with rotor are balanced in compliance with CEI EN 60034-14, R degree; lower degrees are possible.

Thermal protections

Devices capable of providing accurate protection of the winding when the temperature increases. Bi-metal thermal protection (PTO) or thermistor thermal protection (PTC).

Forceventilation

Forceventilation permits better cooling in case of lower speed than the nominal. It allows the complete torque and reduce the noise level at maximum speed.

Size	Power (W)	Current (A)	Voltage (V)	Frequency (Hz)
E63	16	0,2 - 0,18	1~ 220-240Vac	50 / 60
E80	39	0,28 - 0,24	1~ 220-240Vac	50 / 60

ER DIN 6499 Collect available on demand

ER16

M22x 1,5 nut, Ø16 nominal size collect for Ø1- 10 mm tools.

ER20

M25x 1,5 nut, Ø20 nominal size collect for Ø1- 13 mm tools.

ER25

M32x 1,5 nut, Ø25 nominal size collect for Ø1,5- 16 mm tools.

ER32

M40x 1,5 nut, Ø32 nominal size collect for Ø2- 20 mm tools.

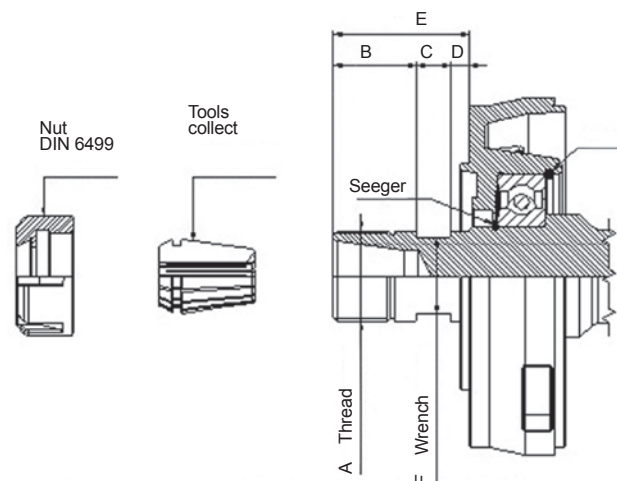

Collect size	A	B	C	D	E	F
ER16	M22x1,5	18	10	9	37	18
ER20	M25x1,5	18	10	9	37	20
ER25	M32x1,5	29,5	12	6,5	48	27
ER32	M40x1,5	35,5	15	6,5	57	35

Motors are supplied with DIN 6499 nut only, collet excluded

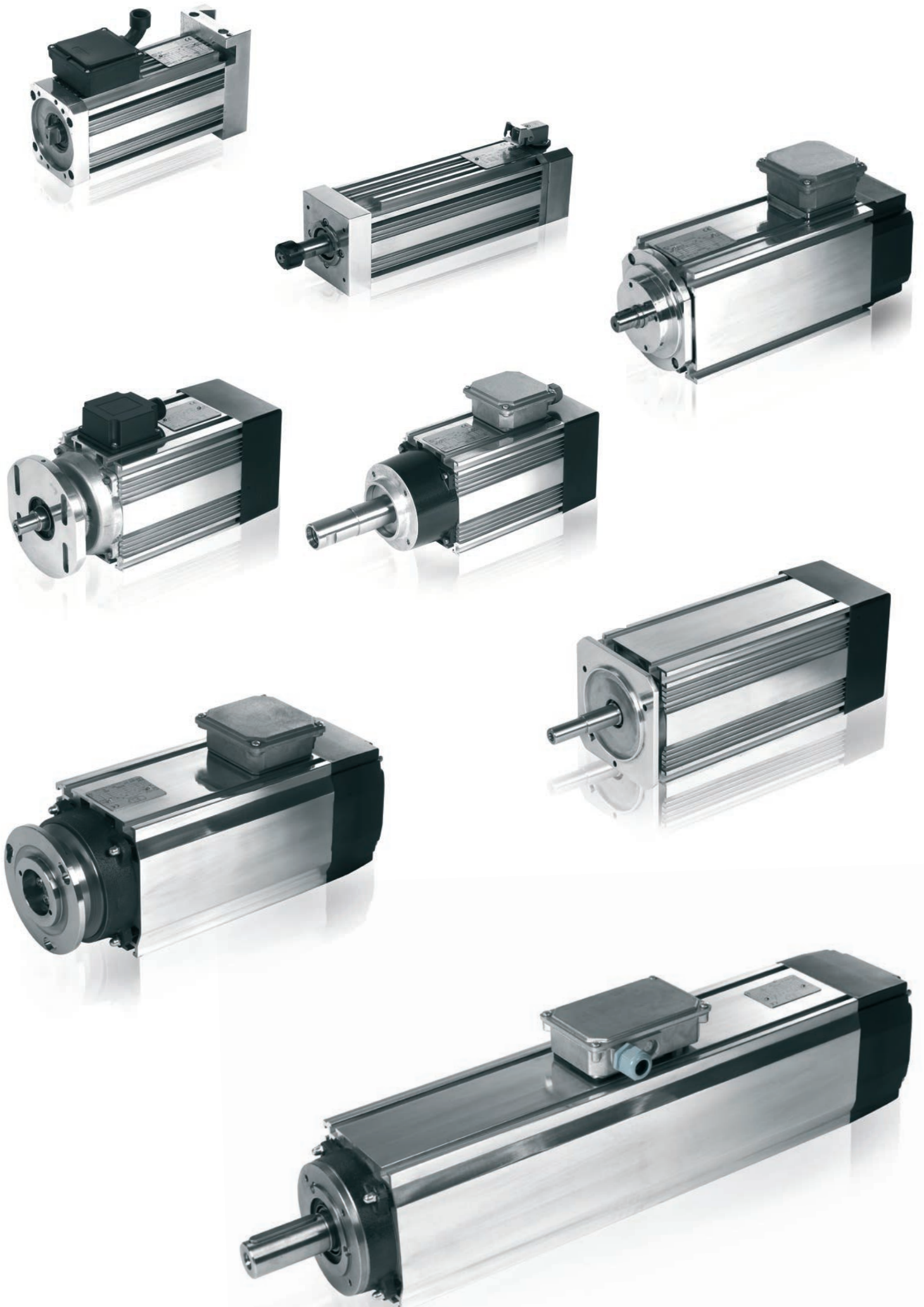

E48 - Explosion views

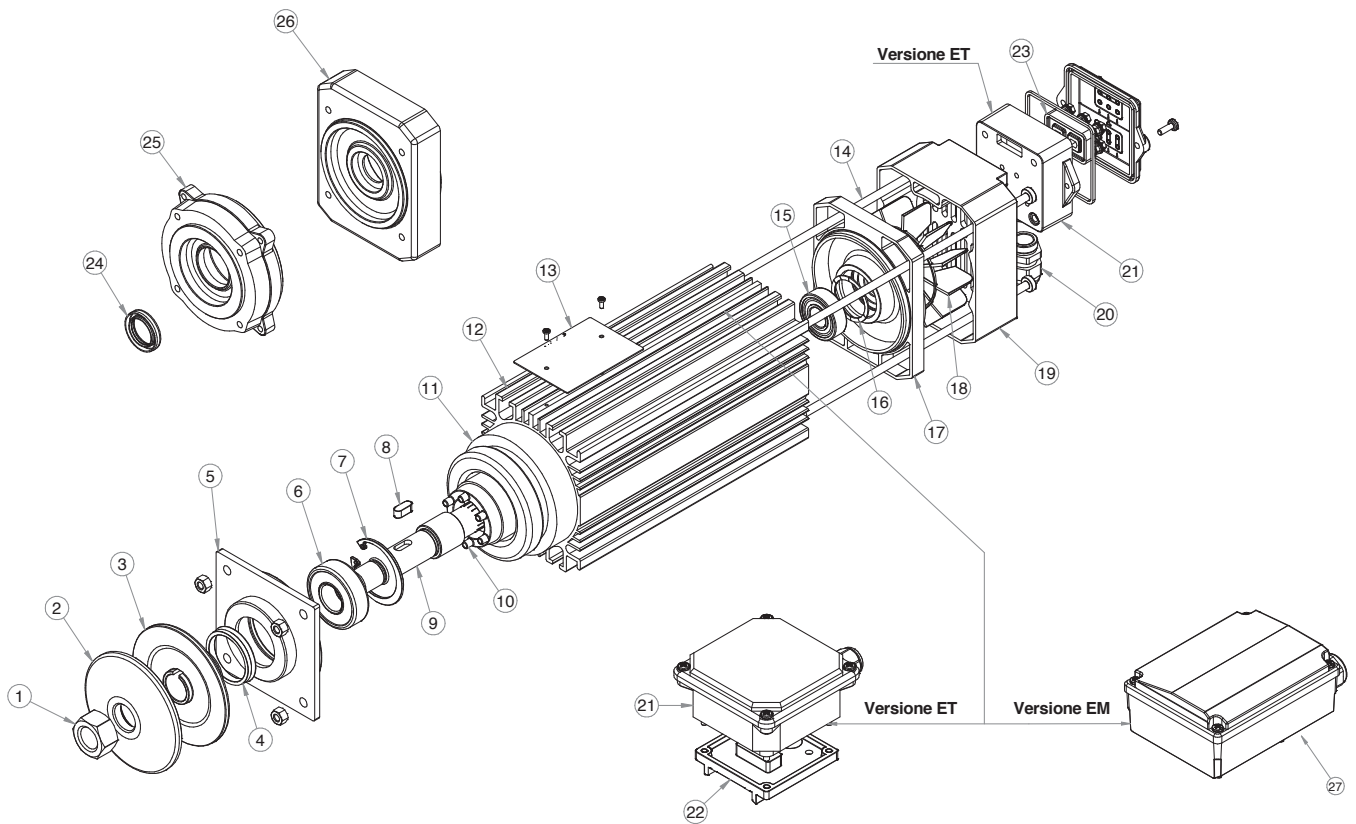

1	blade nut	15	rear bearing
2	blade clamping disc	16	pre load washer
3	blade holding disc	17	end shield (no drive end)
4	dust seal Vring	18	cooling fan (PVC)
5	B3 end shield (drive end)	19	fan cover
6	front bearing	20	cable gland
7	circlip (seeger)	21	terminal box
8	shaft key	22	underbase
9	shaft	23	terminal board
10	rotor	24	oil seal
11	stator assembly	25	B14 IEC71 flange
12	casing	26	B14 IEC80 flange
13	nameplate	27	capacitor holder box (EM)
14	tie rod		

E60 - Explosion views

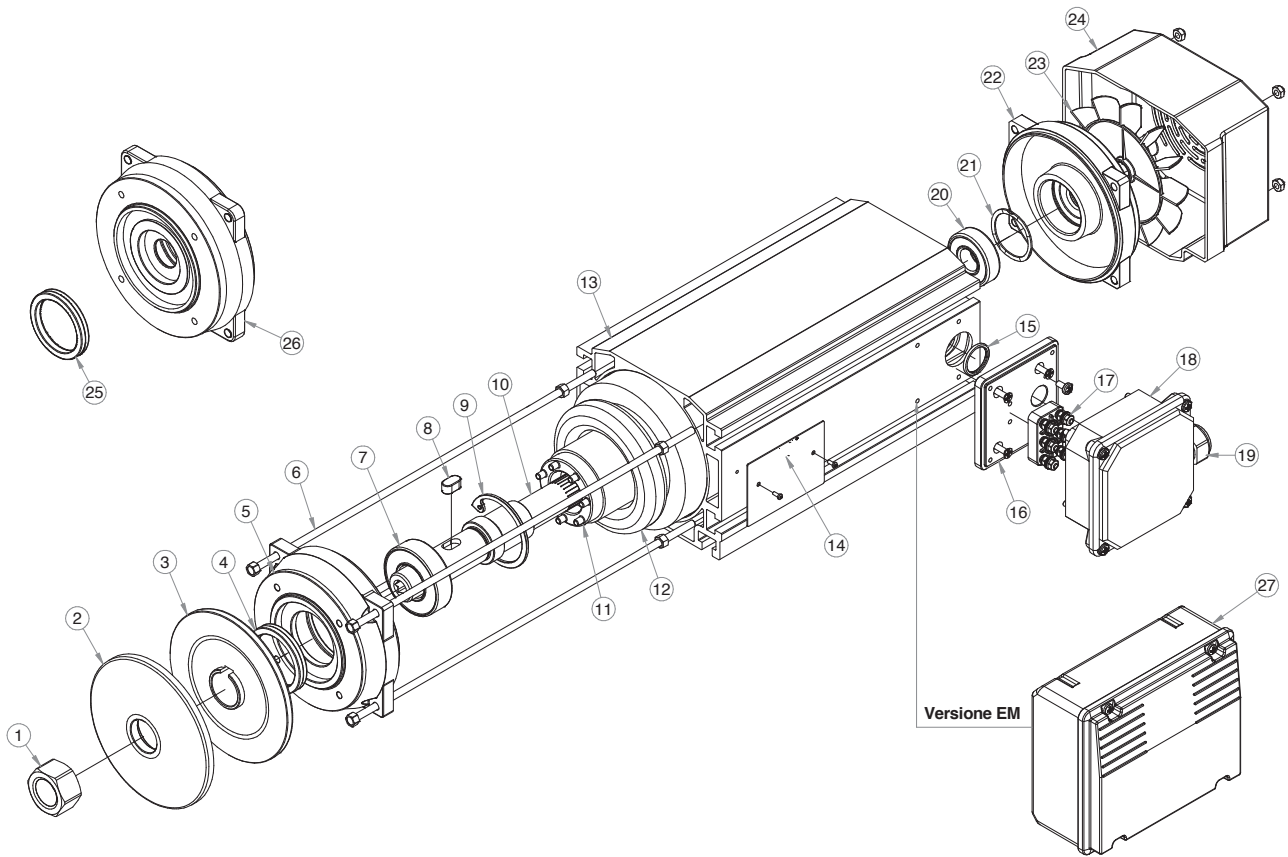

1	blade nut	15	"O" ring
2	blade clamping disc	16	underbase
3	blade holding disc	17	terminal board
4	dust seal Vring	18	terminal box
5	B14 IEC71 flange	19	cable gland
6	tie rod	20	rear bearing
7	front bearing	21	pre load washer
8	shaft key	22	end shield (no drive end)
9	circlip (seeger)	23	cooling fan (PVC)
10	shaft	24	fan cover
11	rotor	25	oil seal
12	stator assembly	26	B14 IEC80 flange
13	casing	27	capacitor holder box (EM)
14	nameplate		

E63 - Explosion views

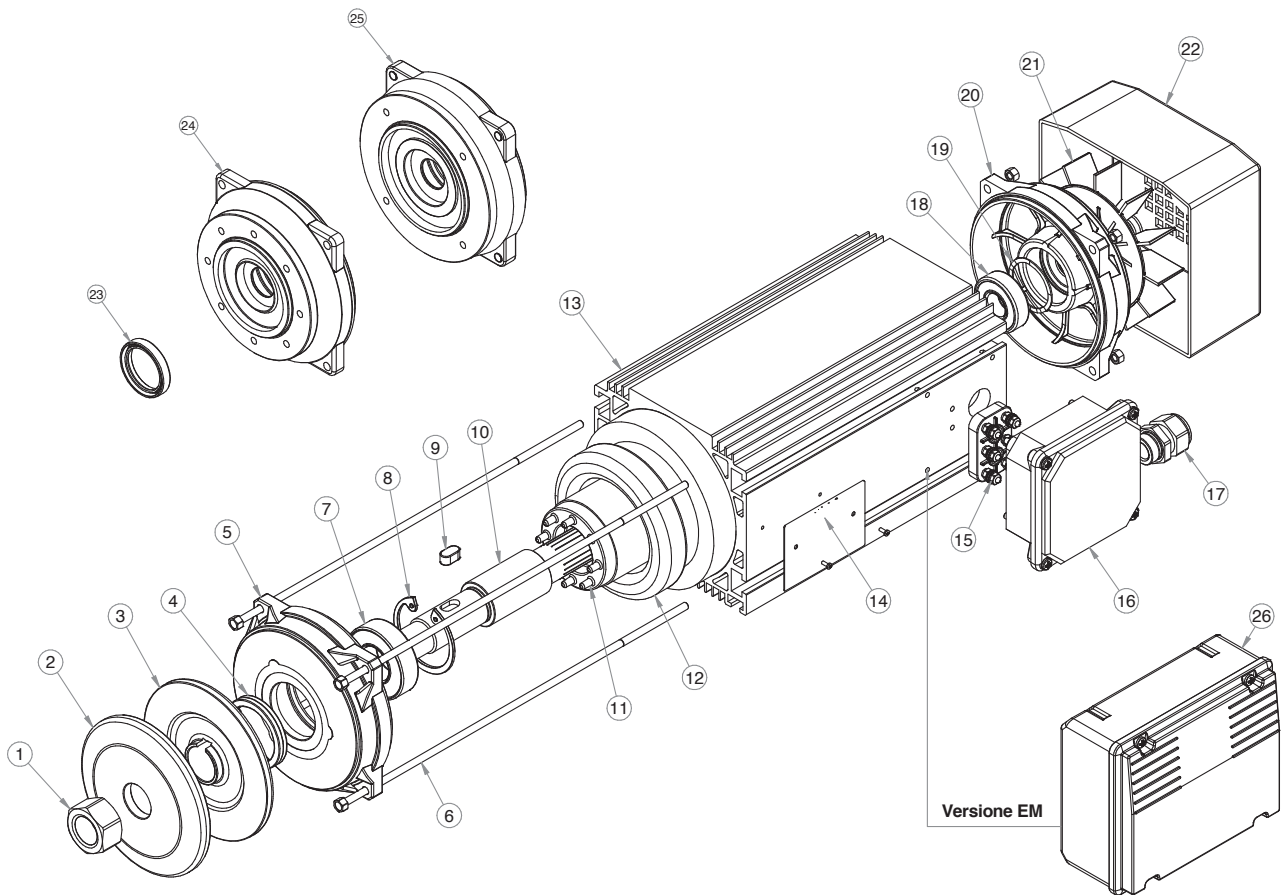

1	blade nut	14	nameplate
2	blade clamping disc	15	terminal board
3	blade holding disc	16	terminal box
4	dust seal Vring	17	cable gland
5	B3 end shield (drive end)	18	rear bearing
6	tie rod - tirante	19	pre load washer
7	front bearing	20	end shield (no drive end)
8	circlip (seeger)	21	cooling fan (PVC)
9	shaft key	22	fan cover
10	shaft	23	oil seal
11	rotor	24	B14 IEC71 flange
12	stator assembly	25	B14 IEC80 flange
13	casing	26	capacitor holder box (EM)

E80 - Explosion views

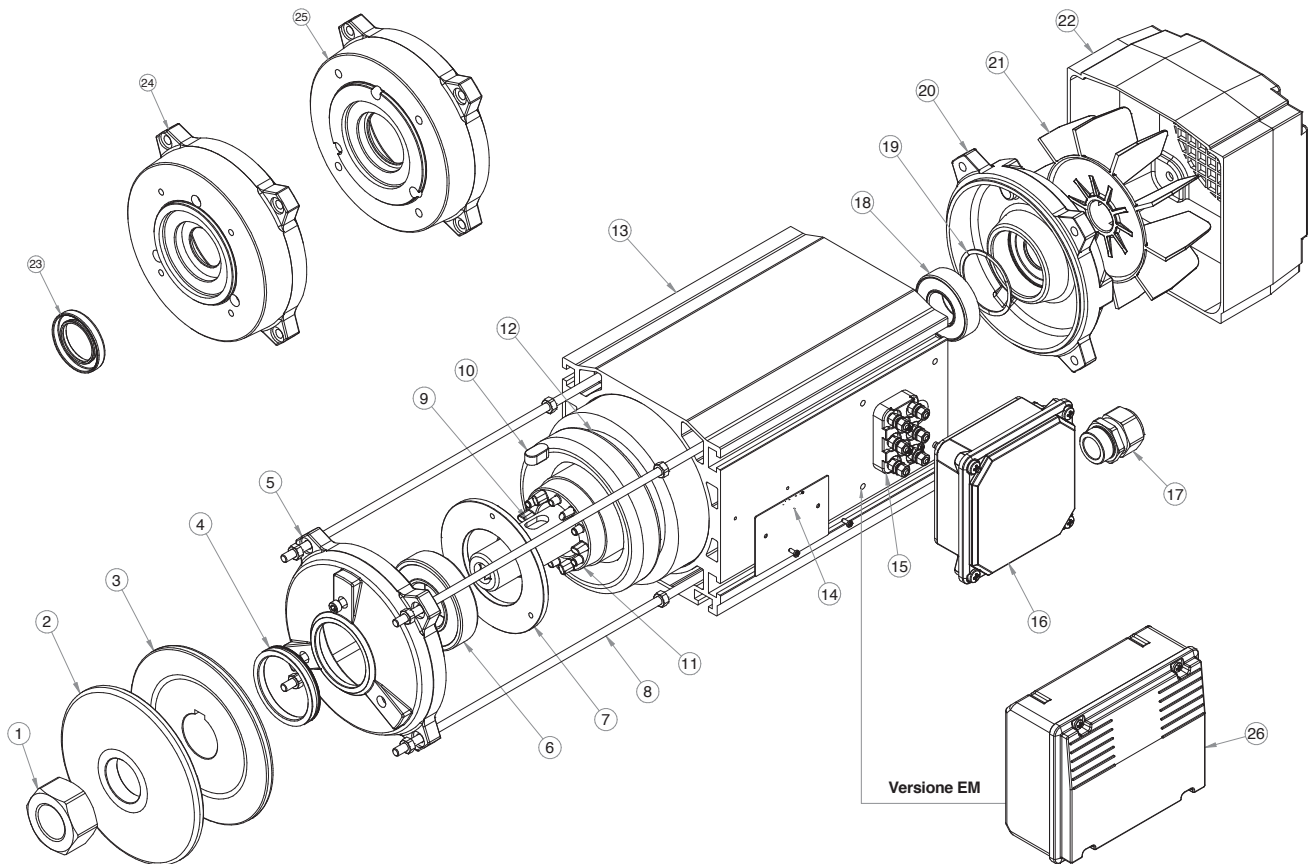

1	blade nut	14	nameplate
2	blade clamping disc	15	terminal board
3	blade holding disc	16	terminal box
4	dust seal Vring	17	cable gland
5	B3 end shield (drive end)	18	rear bearing
6	front bearing	19	pre load washer
7	discoblock	20	end shield (no drive end)
8	tie rod	21	cooling fan (PVC)
9	shaft	22	fan cover
10	shaft key	23	oil seal
11	rotor	24	B14 IEC71 flange
12	stator assembly	25	B14 IEC80 flange
13	casing	26	capacitor holder box (EM)

